

Installation instructions

Transport | Installation | Operation | Maintenance

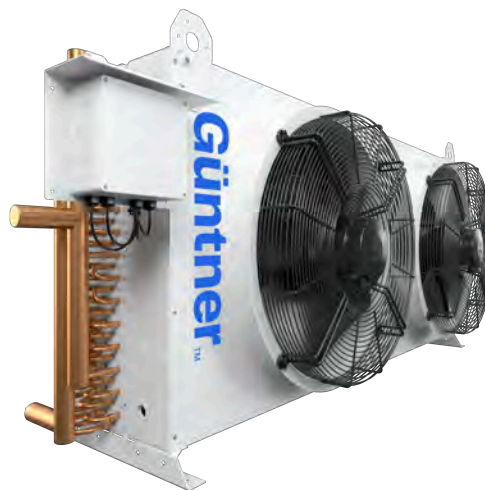

Product line:	dry cooler
Model range description:	Dry cooler – axial, vertical
Model range:	GFV

guntner.com/uk

Contents

1	Important basic information.....	5
1.1	Safety instructions.....	5
1.1.1	Observing the instructions.....	5
1.2	Importance of the EN 378 series of standards – refrigeration systems and heat pumps – safety-related and environmental requirements.....	5
1.3	Responsibilities.....	5
1.3.1	Manufacturer's responsibilities.....	5
1.3.2	Responsibilities of the system's installer.....	6
1.3.3	Owner or operator responsibilities.....	6
1.4	Legal notes.....	7
1.5	Instructions.....	7
1.5.1	Scope.....	7
1.5.2	Set-up and other applicable documents.....	8
1.6	Conventions.....	8
1.6.1	Typographical conventions.....	8
1.6.2	List of abbreviations.....	8
1.7	Conventions for safety signs and notices.....	9
1.7.1	General safety symbols and their meanings in these instructions.....	9
1.7.2	Warning symbols and their meaning in these instructions.....	9
1.7.3	Prohibitory signs and their meaning in these instructions.....	10
1.7.4	Mandatory signs and their meaning in these instructions.....	10
2	Safety.....	12
2.1	Labelling on the unit.....	12
2.1.1	Safety signs on the unit.....	14
2.1.2	Labelling on the packaging.....	16
2.1.3	Other signs and notes on the unit or packaging.....	18
2.2	Basic safety notices.....	21
2.2.1	How to act in an emergency.....	21
2.2.2	Personnel, care requirements.....	22
2.3	Proper intended use.....	22
2.3.1	Use according to the intended purpose.....	22
2.3.2	Operating conditions.....	22
2.3.3	Improper use.....	24
2.4	Mechanical residual hazards.....	25
2.4.1	Fins, sharp unit corners and edges.....	25
2.4.2	Fans.....	26

2.5	Electrical residual hazards.....	26
2.6	Thermal residual hazards.....	27
2.6.1	Danger of burns.....	27
2.6.2	Frost hazard.....	27
2.7	Residual hazards due to the heat carrier glycol.....	28
2.8	Residual hazards caused by vibrations.....	30
2.9	Residual hazards caused by pressurised parts.....	30
2.10	Residual hazards caused by defective installation.....	31
2.11	Residual hazards with break during operation.....	32
2.12	Residual hazards caused by escaping objects or liquids.....	33
2.13	Residual hazards with disposal.....	33
3	Technical data.....	35
3.1	Heat exchanger (typical values).....	35
3.2	Fans.....	35
4	Set-up and function.....	37
5	Fan motor.....	38
6	Transportation and storage.....	39
6.1	Safety.....	39
6.2	Transportation and storage.....	39
6.3	Storage before installation.....	41
7	Set-up and start-up.....	42
7.1	Safety.....	42
7.1.1	Safety instructions for set-up and start-up.....	42
7.1.2	System-side safety requirements.....	44
7.1.3	Customer-side safety precautions.....	45
7.2	Requirements as regards the place of installation.....	46
7.3	Unpacking the unit.....	47
7.4	Installation.....	49
7.4.1	System-side requirements for stress-free installation.....	49
7.4.2	Mounting the vibration dampers (optional).....	50
7.5	Notes on connecting the unit.....	51
7.5.1	Connect the unit to the heat carrier circuit of the system.....	52
7.5.2	Unit electrical connection and protection.....	52
7.6	Perform acceptance test.....	53
7.7	Test readiness for operation.....	54
7.8	Putting the unit into operation for the first time.....	55
8	Operation.....	56
8.1	Safety.....	56
8.2	Putting the unit into operation.....	56

	8.3	Taking the unit out of operation.....	56
	8.3.1	Shutdown, dismantling and disposal.....	57
	8.4	Shutting the unit down.....	57
	8.5	Putting the unit into operation after a shutdown.....	58
	8.6	Changing the unit over to another working fluid.....	58
9		Troubleshooting.....	60
	9.1	Safety.....	60
	9.2	Service.....	60
	9.3	Troubleshooting table.....	60
10		Maintenance.....	62
	10.1	Safety.....	62
	10.1.1	Before starting all maintenance.....	62
	10.1.2	With all maintenance work.....	63
	10.1.3	After all maintenance work.....	64
	10.2	Inspection and maintenance plan.....	64
	10.2.1	Fans.....	64
	10.2.2	Unit heat exchanger.....	65
	10.3	Maintenance work.....	65
	10.3.1	Remove leaks.....	65
	10.4	Clean unit.....	66
	10.4.1	General.....	66
	10.4.2	Defrost heat exchanger.....	66
	10.4.3	Cleaning fans.....	69
11		Plans/diagrams.....	70
	11.1	Electrics documentation.....	70
	11.1.1	Fan motor connection diagram.....	70

1 Important basic information

1.1 Safety instructions

1.1.1 Observing the instructions

⚠ CAUTION

- ▶ Always keep the instructions in the unit's immediate vicinity at all times.
- ▶ Ensure that the instructions are accessible to all people that have anything at all to do with the unit at all times.
- ▶ Ensure that the instructions are read and understood by all people that have anything at all to do with the unit.

1.2 Importance of the EN 378 series of standards – refrigeration systems and heat pumps – safety-related and environmental requirements

EN 378 deals with safety-related and environmental requirements for designing, constructing, producing, installing, operating, maintaining and disposing of refrigeration systems and cooling equipment.

EN 378 is oriented towards manufacturers, installers and operators of refrigeration systems and cooling equipment (see section 1.2. Responsibilities).

The objective of EN 378 is to restrict the possible hazards of refrigeration systems, cooling equipment and their working fluids (refrigerants and coolants) for people, property and the environment to a minimum.

Insufficient safety measures or non-compliance with safety-relevant regulations can result in:

- Breaks or ruptures on components with the danger of escaping materials (hazards caused by the influence of low temperatures, excess pressure, direct influence of the fluid phase, moving machine parts).
- Escaping working fluid after a break or leak because of defective design, improper operation, insufficient maintenance, repairs, filling and disposal (hazards caused by flammability, explosion hazard, disturbance of nervous system, suffocation, panic)

1.3 Responsibilities

1.3.1 Manufacturer's responsibilities

The notes provided in these instructions on maintaining the unit's functional safety, on preventing possible hazards during transport, set-up and installation, start-up and operation as well as maintenance activities (cleaning, servicing and repairing) refer exclusively to the unit.

The manufacturer's responsibilities are documented in the unit's version in acc. with EN 378-2 (design, manufacture and testing).

The materials used in the construction and for welding are designed to withstand the foreseeable mechanical, thermal and chemical stresses, and are resistant to the working fluids used.

The working fluid-carrying parts of the unit (core tubes, distributor tube and header outlet) are configured so that they remain tight with the foreseeable mechanical, thermal and chemical stresses, and withstand the maximum permissible operating pressure.

Material, wall thickness, tensile strength, corrosive resistance, shaping process and testing are suitable for the working fluid used and withstand the possible pressures and stresses that might occur.

All responsibility for the equipment into which the unit is integrated, are the exclusive responsibility of the people involved in the individual workflows.

1.3.2 Responsibilities of the system's installer

The responsibilities of the system installer including the heat carrier circuit are documented in the system's version (design, manufacture and testing – in accordance with EN 378-2.

Interfaces between component supplier – installer of the system:

- Güntner GmbH & Co. KG In the event of a fault:
In the event of problems during set-up, installation, start-up and operation, immediately contact Güntner GmbH & Co. KG.

The responsibilities of the system installer in particular include:

- Planning and preparing emergency measures:
To avoid consequential damage caused by operational disruptions, a warning system which immediately signals all faults must be provided on-site. Prepare emergency measures that prevent consequential damage for people and property should faults occur.
- Specify checking and maintenance intervals:
The system including the heat carrier circuit must be configured and equipped with all required equipment for maintenance and sufficient servicing and testing in accordance with EN 378-4.

When the unit is integrated into the refrigeration system's heat carrier circuit, the unit's working fluid and version must not deviate from the order-related information specified in the order-related documents.

The installer of the system including the heat carrier circuit must refer to the requirement for sufficient instruction of the operating and supervision staff when operating and maintaining the equipment.

It is recommended that the future customer staff – if possible – be present during the set-up and installation, for tightness tests and cleaning, while the system is being filled with working fluid and for the adjustment of the equipment including the heat carrier circuit.

1.3.3 Owner or operator responsibilities

The owner or operator responsibilities are documented in the operation, maintenance, servicing and recovery of the system including the heat carrier circuit in accordance with EN 378-4.

The owner or operator must ensure that the proper people are sufficiently trained and qualified for operating, monitoring and servicing the system including the heat carrier circuit.

The operating personnel for the system and the heat carrier circuit must have sufficient knowledge and experience with regard to the mode of operation, operation and daily monitoring of this system including the heat carrier circuit.

Before starting up the system including the heat carrier circuit the owner or operator must ensure that the operating personnel are adequately instructed about the system's documentation (which these instructions belong to) on the set-up, monitoring, mode of operation and maintenance of the system including the heat carrier circuit and about the safety measures to be observed as well as the properties and handling of the working fluid to be used.

The owner or operator must ensure that when operating, monitoring and maintaining the system including the heat carrier circuit the working fluid and version must not deviate from the details specified in the order-related documents.

Planning and preparing emergency measures: To avoid consequential damage caused by operational disruptions, a warning system must be installed on the customer's premises. Prepare emergency measures that prevent consequential damage for people and property should faults occur.

Responsibility remains with the owner or operator of the system including the heat carrier circuit, if the system including the heat carrier circuit is used by anybody else, unless there is a contrary agreement on sharing responsibility.

If you operate units that are wetted or sprayed with water, you must observe the contents of the VDI guideline 2047-2 "Requirements for the hygienic operation of cooling towers", the specifications of the 42nd BImSchV (Federal Immission Control Ordinance) and the VD-MA leaflet "Notes and recommendations for operating and maintaining evaporation cooling plants" ("Hinweise und Empfehlungen zum Betrieb und zur Wartung von Verdunstungskühlanlagen").

1.4 Legal notes

Warranty claim expires as follows:

- With faults and damage that can be attributed to non-compliance with the requirements set out in these installation instructions.
- With complaints that can be attributed to use of spare parts other than the original spare parts specified in the order-related offer documents.
- With changes to the unit (working fluid, version, function, operating parameters) vis-a-vis the order-related information specified in the order-related offer documents without the manufacturer's prior consent.

Without prior explicit written approval of Güntner GmbH & Co. KG the instructions may not be reproduced electronically or mechanically, circulated, changed, passed on to third parties, translated or used otherwise, in full or in part.

1.5 Instructions

1.5.1 Scope

These instructions apply to dry coolers in the model range GFV.

The units are components of a system, e.g. for conditioning and circulating the room air in storage rooms

NOTICE

You will find the precise type of your unit in the attached order-related documents.

1.5.2 Set-up and other applicable documents

The unit's instructions include the following parts:

- These instructions
- Order-related documents
The order-related documents are attached to these instructions and include the following information:
 - The order-related proper use as specified
 - The order-related scope of delivery
 - The order-related technical data
 - The order-related drawings specifying customer, project number and order number
- Motor connection wiring diagram in terminal boxes

These instructions are part of the operating instructions manual of the system provided by the installer of the system including the heat carrier circuit.

1.6 Conventions

1.6.1 Typographical conventions

The following text markups are used in these instructions:

Bold	Requires special attention!
Grey triangle	Instructions

1.6.2 List of abbreviations

Abbreviations	Meaning
EN 378	European Norm 378: Refrigeration systems and heat pumps; safety-related and environmental requirements
EN	European Norm
DIN	German industrial standard (specification of a standard)
ISO	International Standardization Organization .
°C	Degrees Celsius (Celsius scale temperature)
bar	Unit of pressure
l	Litre (liquid volume)
Vol%	Volume percent (concentration level relative to a volume)
IP	Insulation protection

Abbreviations	Meaning
Q 6,3	Balancing quality
ppm	parts per million, concentration figure, stands for “millionth part”
Hz	Hertz (frequency)
D	Delta connection (alternating current: high speed)
S	Star connection (alternating current: low speed)
3~	3-phase current
1~	1-phase alternating current
VDE	“Verband der Elektrotechnik, Elektronik und Informationstechnik” (Association for Electrical, Electronic & Information Technologies)
TCC	Technical Connection Conditions
EPC	Electric Power Company
VDI	“Verein Deutscher Ingenieure” (German engineers’ association)

1.7 Conventions for safety signs and notices

1.7.1 General safety symbols and their meanings in these instructions

⚠ DANGER
Dangerous situation that will definitely cause serious injury or death if it is not avoided.
⚠ WARNING
Dangerous situation that could cause serious injury or death if it is not avoided.
⚠ CAUTION
Dangerous situation that could cause slight to moderate injury if it is not avoided.
NOTICE
Refers you to possible damage to property.

1.7.2 Warning symbols and their meaning in these instructions



Warns against hand injuries!

Failure to comply with warnings may result in hands or fingers being crushed, dragged in or otherwise injured.



Warns against hot surfaces!

The temperature is over +45°C (at which protein clots) and can cause burns.



Warns against dangerous electrical voltage!

Danger of an electric shock if voltage-carrying parts are touched.



Warns against fire-risk substances at set-up point.

Use of ignition sources can cause fire at set-up point.



Warns against harmful to health or irritant substances at set-up point

Contact with or inhaling substances that are irritant or harmful to health can cause injuries or damage peoples' health.



Warning of automatic start-up

If the unit starts up automatically during maintenance work there is a danger of pinching/trapping the hands and fingers.

1.7.3 Prohibitory signs and their meaning in these instructions



Fire, open fire and smoking prohibited!

Ignition sources must be kept away and ignition sources must not develop!



No smoking!

Smoking is forbidden.



No entry!

It is prohibited to enter the marked area.

1.7.4 Mandatory signs and their meaning in these instructions



Use eye protection!

Eye protection: Use protective cover, protective glasses or face protection.



Use hand protection!

Protective gloves must protect against mechanical and chemical dangers (see imprinted pictograms).



Use respiratory protection!

Breathing apparatus must be suitable for the working fluid used. Breathing apparatus must consist of:

- At least two independent breathing devices (self-contained breathing apparatus)



Use protective clothing!

Personal protective clothing must be suitable for the working fluid used and for low temperatures, and must have good heat insulation properties.



Disconnect prior to work!

Disconnect the electrical system and secure against switching on again before starting installation, maintenance and repair work.

2 Safety

2.1 Labelling on the unit

Position of the labels on the unit

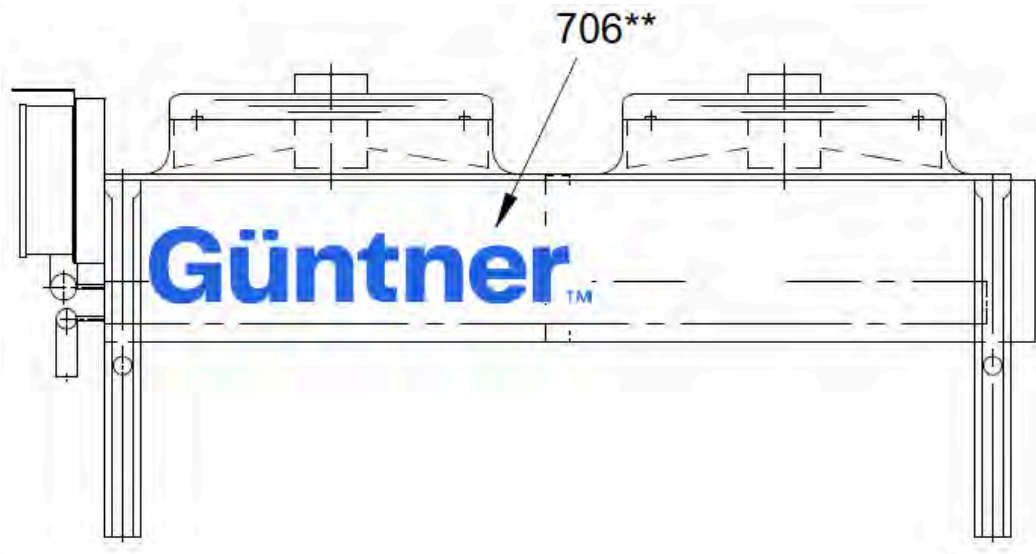

Front view (FLAT)

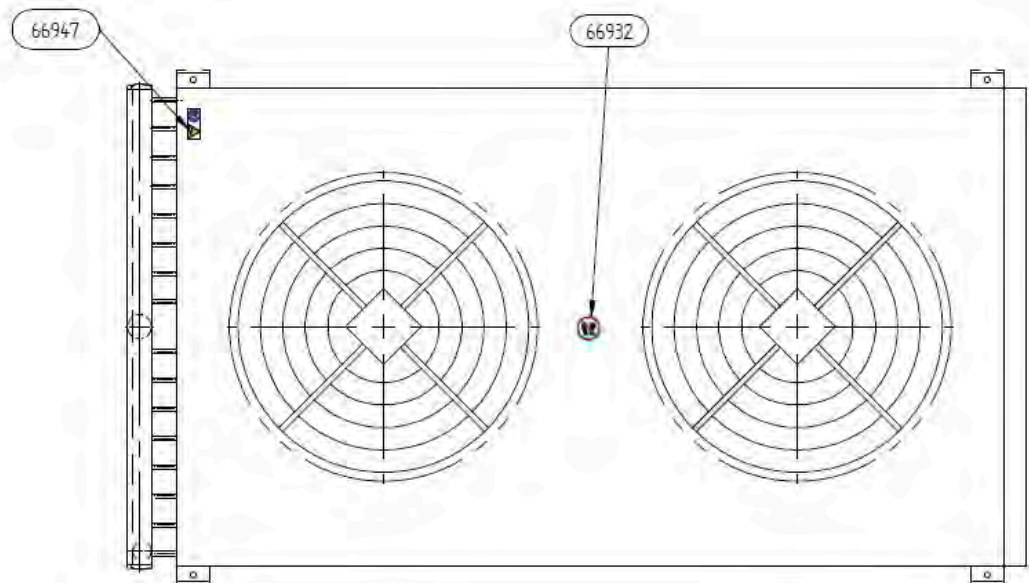

View from above (FLAT)

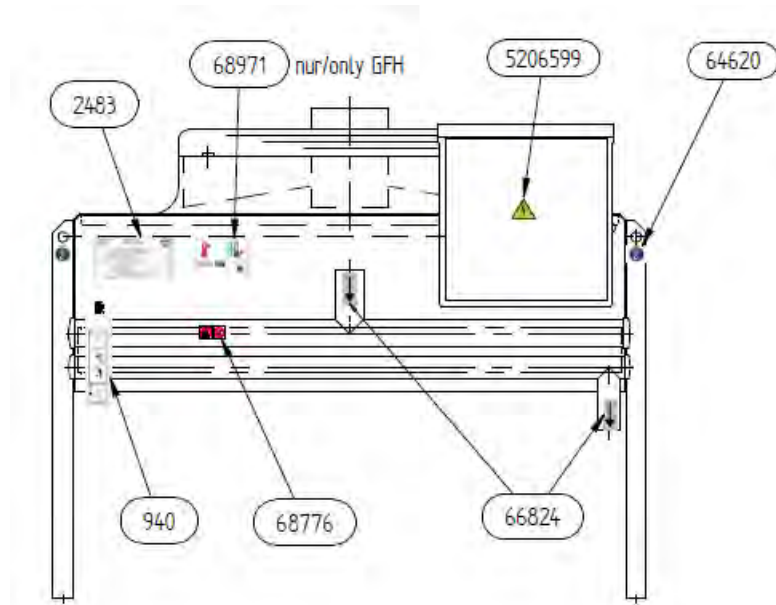

Side view (FLAT)

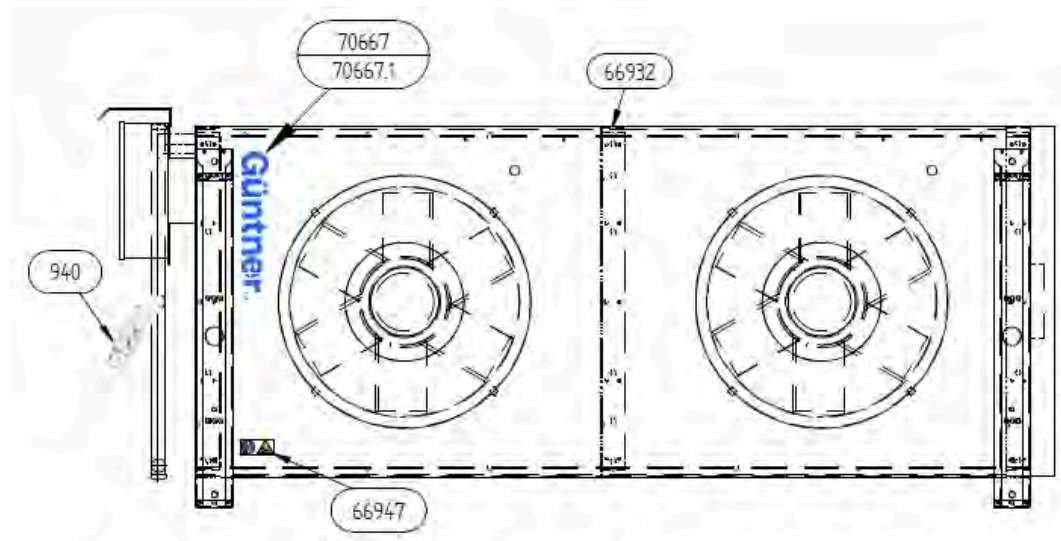

Front view (VERTICAL)

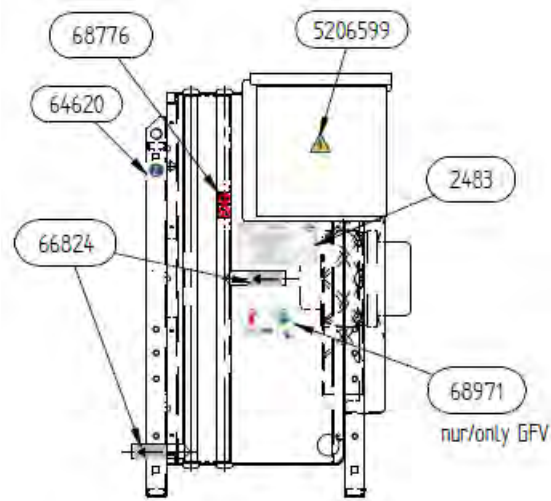

Side view (VERTICAL)

2.1.1 Safety signs on the unit

Safety signs on the unit individually:



940 - "Transportation filling" warning sign next to Schrader valve



66947 - Mandatory signs/warning signs: Disconnect power/Warning about hand injuries



64620 - Lifting point



60325, 68776 - "Do not load. Do not lift" warning.

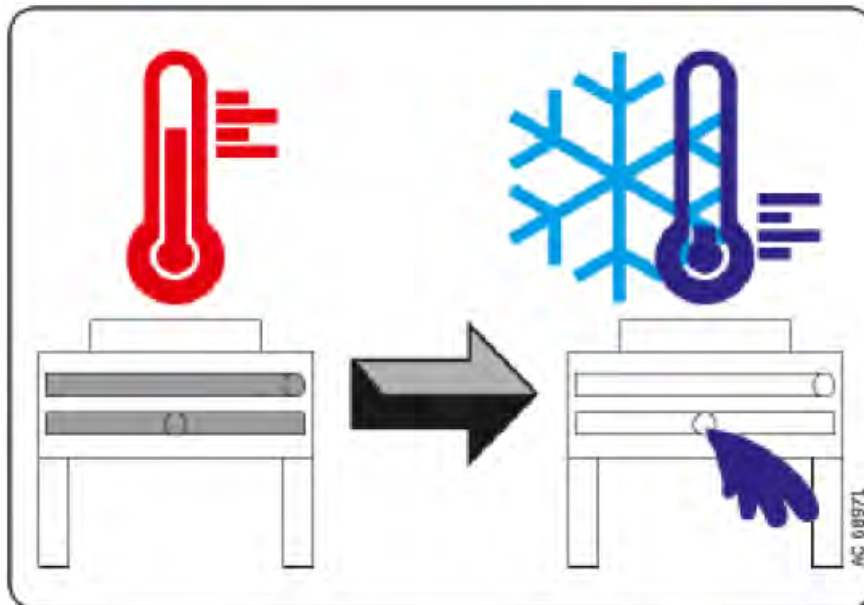

68971 - Danger of frost for dry coolers in general (only for dry coolers/flange connection)



5206599 - Electrical voltage warning (for electrical systems)



3872 - Earthing identifier



66932 - "No entry" warning sign

2.1.2 Labelling on the packaging

Labels on the packaging

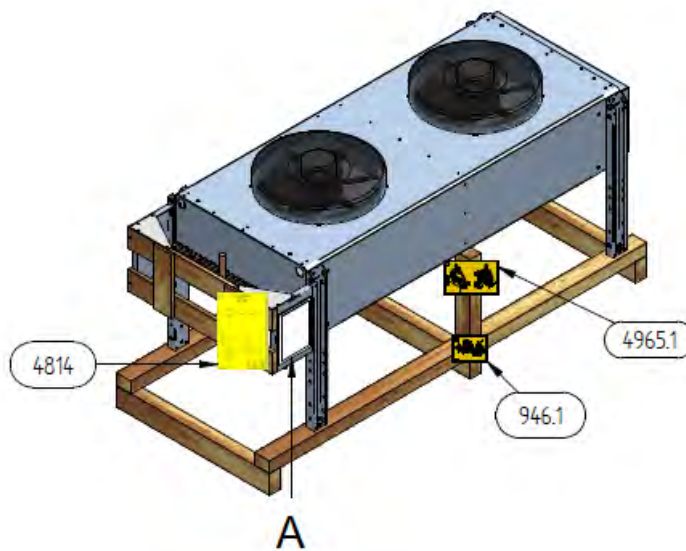

Packaging (FLAT)

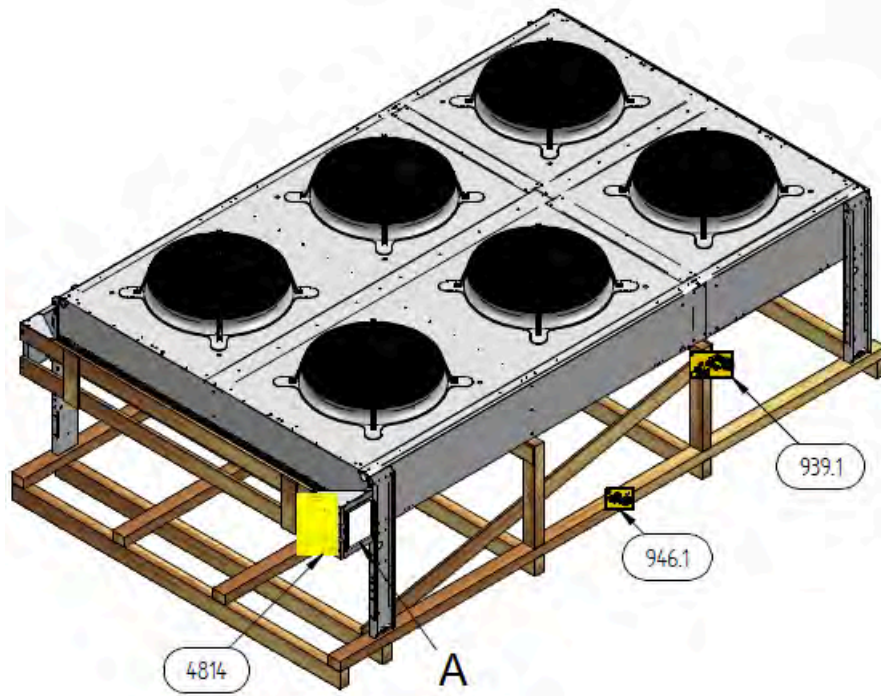

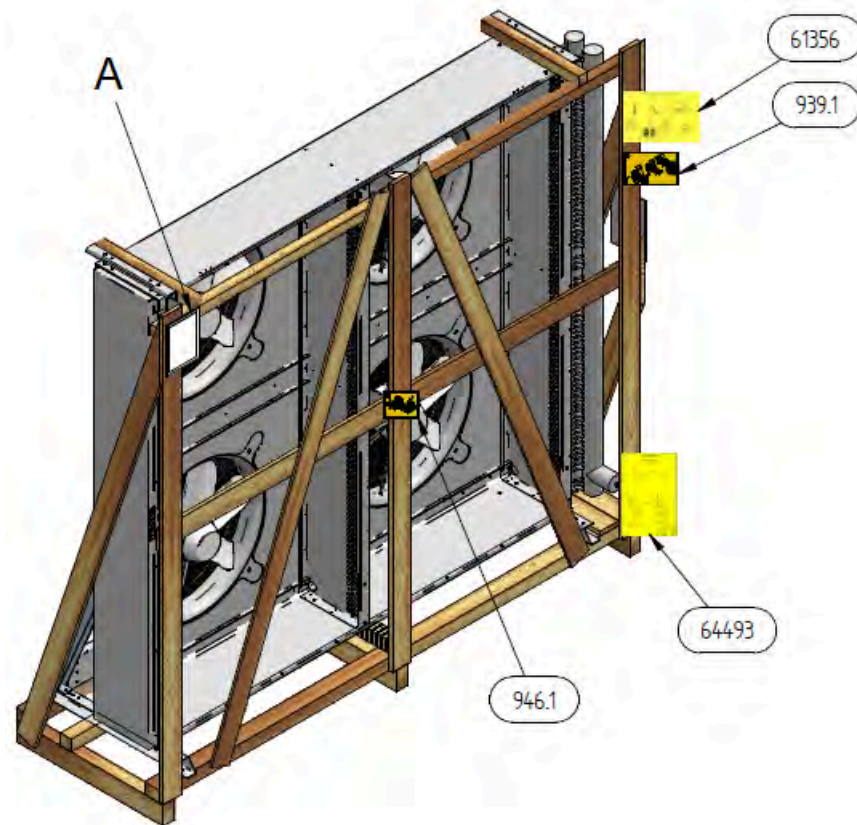

Packaging double-row (FLAT)



Packaging (VERTICAL)

A - Intralogistics label

2.1.3 Other signs and notes on the unit or packaging

Güntner GmbH & Co.KG Hans-Güntner-Straße 2-6 82256 Fürstenfeldbruck www.guentner.de		 0036 PED *  II 2G IIB T4			
Projektnummer – Project number	101014529				
Gerätebezeichnung - Unit name	GVH 100.3B/2x4-L(S).E				
Gerät Seriennummer - Device serial number	404157434/52.00042				
Ventilator / ID / Drehzahl - Fan / ID / Speed	VT01407 / 2008 / 480 min -1				
Umgebungstemperatur – Air ambient temperature	-30°C / +50°C				
Herstellungsjahr - Year of manufacture	2015				
*Druckgerät Seriennr. – pressure equipment serial no.	404157435/52.02100				
Volumen – Volume (V)	297.5 l				
Max. zulässiger Druck (PS) Max. allowable pressure (PS)	32 / 0 bar	24 / 0 bar	0 / -1 bar		
Zulässige min./ max. Temperatur (TS) Allowable min./ max. temperature (TS)	-10°C / +100°C	-50°C / -10°C	-5°C / +40°C		
Prüfdruck (PT) / Prüfmedium Test pressure (PT) / Test medium	35,2 bar / Druckluft - Compressed air				
Prüfdatum - Test date	15.02.2015				
Fluidgruppe / Zustand - Group of fluid / State	2 / gasförmig - gaseous				

2483 - Example of a nameplate



706**, 2118, 2119 – Güntner logo



66824 and 68909 - Connections IN and OUT

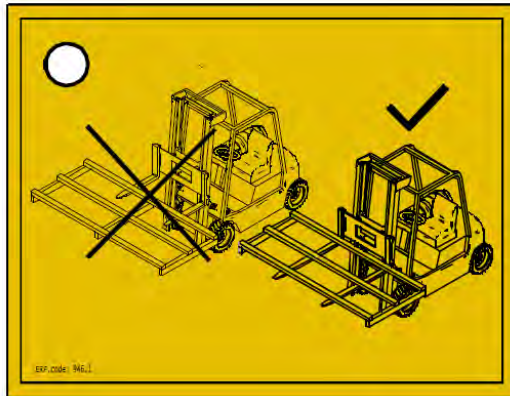

946.1 - Fork-lift transport

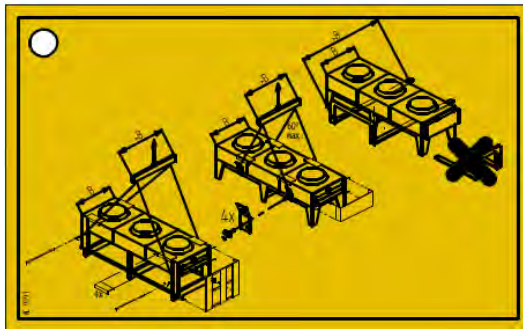

939.1 - Transport regulation

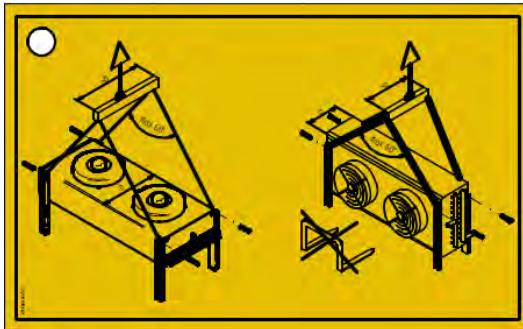

4965.1 - Transport regulation up to a diameter of 067 for units with a base width of 75 mm

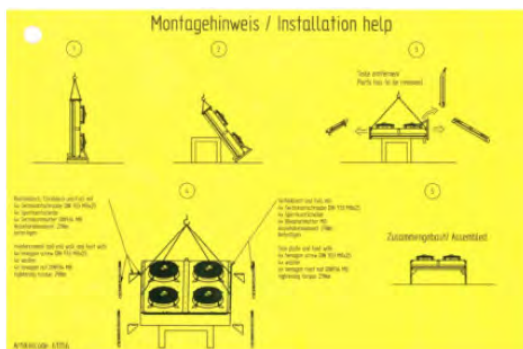

61356 - Installation instructions, for double-row units



70274 - Only for transport

Only for units with optional vibration damper; for mounting the vibration dampers (supplied loose) see "Mounting the vibration dampers (optional)", page 50

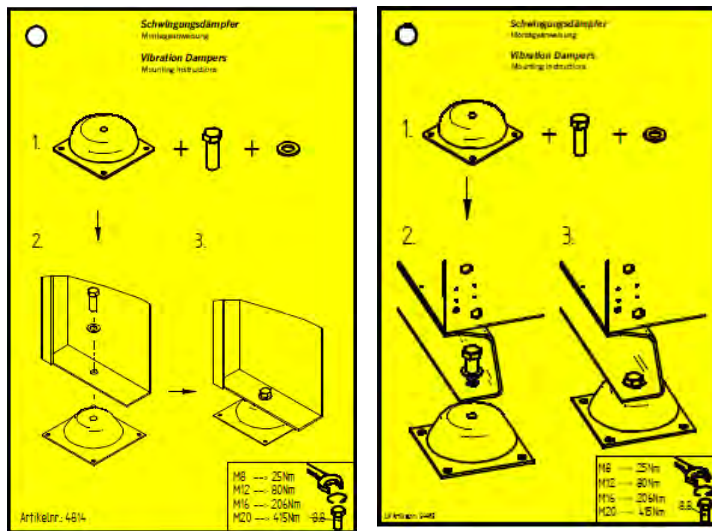

4814, 64493 - Notice for vibration damper

2.2 Basic safety notices

2.2.1 How to act in an emergency

⚠ WARNING









Danger of injuries and damage to property!
The unit is operated as standard with the heat carrier ethylene glycol (synonyms: ethane-1,2-diol, glycol). Prior agreement with the manufacturer is imperative when using other heat carriers.
Ethylene glycol is a colourless, slightly viscous, not very fluid, water-mixable, deliquescent liquid with a sweet smell or taste.
Ethylene glycol is flammable and explosive at higher temperatures in a vapour/gaseous state.
With skin contact ethylene glycol causes slight irritation with the danger of skin absorption; with eye contact mucous membrane irritation; with ingestion agitation with disruption of the central nervous system; with prolonged endangering effect – fatigue, coordination disruption, unconsciousness, kidney damage.
Keep ethylene glycol away from ignition sources. No smoking!
Ethylene glycol vapours are heavier than air and may flow off to rooms on a lower level. In still air there may be an increase of the ground level concentration. With high concentrations, there is a danger of suffocation due to reduced oxygen concentration, especially at ground level.
Avoid contact with skin, floor, clothing! Remove contaminated, soaked clothing immediately!
Do not allow contact with heavy oxidation agents (chromo-sulphuric acid, potassium permanganate, smoking sulphuric acid, or similar)! Danger of strong reactions!
Unauthorised people must not have access to the unit. When setting up it must be ensured that the heat carrier escaping from the unit cannot penetrate the interior of the building or put people at risk in any other way.
Safety measures and procedure:

- In the event of unexpected, serious leakage of heat carrier, activate the emergency procedures provided, e.g. if:
 - There is a visible leak of heat carrier from the heat exchanger or pipeline components.
 - There is a sudden large release (release of the greater part of the entire heat carrier filling in a short time, e.g. in less than 5 minutes).
- Have experienced, trained personnel with prescribed protective clothing perform all necessary protective and other measures:
 - Use respiratory protection.
 - Use a room air-independent breathing apparatus with maintenance work in high heat carrier concentrations in the room air.
 - Ensure the set-up room is well ventilated.
 - Divert escaped heat carrier fluid safely in accordance with EN 378-3.

2.2.2 Personnel, care requirements

⚠ CAUTION

The unit may be installed, put into operation, operated, maintained and repaired only by trained, experienced and qualified personnel. In order to be considered qualified, people who are to be responsible for the operation, maintenance, repair and evaluation of systems and their components must have the necessary training and specialist knowledge for such work, as stipulated in EN 378-1. Qualified or expert means the ability to satisfactorily perform the activities required for the operation, maintenance, repair and evaluation of refrigeration systems and their components.

The unit may be operated by operating personnel that have no specific knowledge of refrigeration engineering, but have sufficient knowledge and experience with regard to the mode of operation, operation and daily monitoring of this system, including the heat carrier circuit. This operating personnel may not make any interventions or settings on the system including the heat carrier circuit.

Changes to the unit, which the manufacturer has first agreed to in writing, may only be made by the instructed and qualified personnel.

Electrical installation:

Work on the electrical equipment may only be performed by personnel that have the required expertise (e.g. an electrician or an electro-technically instructed person), and who are authorised by the operator, in compliance with the respective VDE regulations (and national and international provisions) and the TCCs of the EPCs.

2.3 Proper intended use

2.3.1 Use according to the intended purpose

Dry coolers of the GFV series are heat exchangers for outdoor installation. Dry coolers cool the heat carrier by dissipating heat to the air that is guided over the dry heat transfer surface by fans.

The unit is delivered for operation with a specific operating point:

- Heat carrier flow temperature
- Heat carrier return temperature or circulating heat carrier volume
- Airflow volume
- Air inlet temperature

The specified operating point is given in the order-related documents.

The unit is subject to the following load limits:

Earthquake: 0.1 g (perform an inspection after every earthquake)

Snow load: GFV 5.19 kN/m²

Wind load: GFV 1.14 kN/m²

2.3.2 Operating conditions

The unit is a component of the heat carrier circuit system including its working fluid circuit. The purpose of these instructions, as part of the instructions manual of the system (of which these operating instructions are a part) is to minimise the possible danger to people, property

and the environment from the unit and the working fluid used in it. These dangers are essentially connected with the physical and chemical properties of the working fluid and with the pressures and temperatures that occur in the working fluid-carrying components of the unit see "Residual hazards due to the heat carrier glycol", page 28.

⚠ WARNING

Danger of injuries and damage to property!

The unit may be used only in accordance with the proper intended use. The operator must ensure that when operating, monitoring and maintaining the unit, the fluid used and the mode of operation do not deviate from the order-related information specified in the order-specific documents.

The operator must ensure that maintenance measures are performed in compliance with the instructions manual of the system .

Filling the unit with a different fluid is permitted only following written approval by the manufacturer. You will find the order-related proper use as intended in the order-specific documents.

Do not exceed the max. operating pressure given on the unit's type plate.

2.3.3 Improper use

WARNING

Danger of injuries and damage to property!

Working fluids and their combinations with water or other substances in the working fluid-carrying components have chemical and physical effects from the inside on the materials surrounding them. The unit may be pressurised only with heat carrier. Pressurising the unit with another working fluid results in,

- material, wall thickness, tensile strength, corrosive resistance, shaping process and testing are not suitable for the working fluid used and do not withstand the possible pressures and stresses that might occur.
- the unit would not be resistant to the other working fluid and the combination of the other working fluid and
- the unit not remaining tight during operation and when shut down.
- a possible sudden escape of working fluids could directly endanger people and/or property and the environment.

The maximum permissible operating temperature specified on the type plate must not be exceeded! If the operating temperature is exceeded,

- the unit would be exposed to an impermissibly high pressure (pressure/temperature correlation),
- signs of material fatigue would emerge,

The maximum permissible operating pressure specified on the type plate must not be exceeded! If the operating pressure is exceeded,

- the parts of the unit carrying the working fluid might not withstand the foreseeable mechanical, thermal and chemical stresses and the pressures that may occur during operation and when shut down,
- the unit would not remain tight during operation and when shut down,
- there may be a possible sudden escaping of working fluids after a break or leakage on working fluid-carrying components, which would result in the following dangers:
 - Danger of escaping materials
 - Strong chemical reactivity
 - Suffocation hazard
 - hazards caused by panic reactions,
 - Environmental pollution

⚠ WARNING

Dry coolers must not be used

- where it is possible that short or prolonged effect caused by contact, inhalation or ingestion of the working fluid glycol might result in harmful hazards.
- where it is possible that the specific concentrations of the coolant in a homogeneous mixture with air could ignite.
- where the possibility exists of a sudden large release of the greater part of the entire working fluid filling in a short time (e.g. in less than 5 minutes).

The unit must not be modified without prior written consent of Güntner GmbH & Co. KG. Modifications to the unit are:

- Changing the operating point (as specified in section see "Heat exchanger (typical values)", page 35)
- Changing the fan capacity (air volume)
- Changing the working fluid flow-through volume
- Changing over to another working fluid

The unit must not be operated if safety devices recommended by the manufacturer are not available, not properly installed or not fully functional.

The unit must not be operated if it is damaged or shows signs of faults. All damage and faults must be reported to Güntner GmbH & Co. KG immediately and must be rectified without delay.

Work on the unit must not be performed without the personal protective equipment prescribed in these instructions.

2.4 Mechanical residual hazards

2.4.1 Fins, sharp unit corners and edges

⚠ WARNING





Warns against hand injuries!
Danger of cuts to hands and fingers on the fins and on sharp edges and corners of the unit.



Use reliable hand protection!

2.4.2 Fans

⚠ WARNING



Danger of cutting off, pulling in!
 There is a danger of cutting off fingers on the rotating fan blades, injury hazard for the hands and pulling in danger for loose elements such as hair, necklaces or clothing parts.

Do not operate fans without guard grille. Pinch/trap point hazard!
 With automatic fan start during maintenance work there is a danger of pinching/trapping for the hands and fingers.

Power off the unit before you begin maintenance work with which you must remove the guard grille. Secure the unit against unintentional switching on again by removing the electric fuses for the unit. Secure the unit with a suitable warning sign referring to unintentional switching on.

2.5 Electrical residual hazards

⚠ WARNING

Warns against dangerous electrical voltage!
 Direct and indirect contact with voltage-carrying components such as motors and electrical lines can cause serious injuries or death.

Power off the unit before you begin maintenance work. See the refrigeration system's system documentation for this. Secure the unit against unintentional switching on again by removing the electric fuses for the unit. Secure the unit with a suitable warning sign referring to unintentional switching on.



Please note that the mains cables may also be carrying voltage, even if the unit is powered off.

Work on electrical equipment may be performed only by people that have the required expertise (e.g. an electrician or an electro-technically instructed person) and who are authorised to do so by the operator.

2.6 Thermal residual hazards

2.6.1 Danger of burns

⚠ WARNING

Warns against hot surfaces!
In operation the unit's heat exchanger and pipes have temperatures of over +45 °C. Contact can cause burns.
Use hand protection!

2.6.2 Frost hazard

⚠ WARNING



Warns against frost!
The unit cannot be fully drained without the use of tools!
With insufficient frost protection filling and operation in areas with frost hazard, the unit can freeze.
Operation, standstill and pressure tests are permitted only using the specified resources and agents! At no time during operation, standstill or pressure tests may the temperature of the operating fluid fall below its freezing point, as otherwise the unit (heat exchanger coil) will be destroyed. In the case of risk of freezing, the unit must be fully drained or rinsed with an anti-frost agent until adequate freeze protection is ensured. When draining, the unit must be sufficiently ventilated. Draining must be possible at all times by a descending drain pipe outside the unit. The pressure drop may need to be increased with pressurised air during draining.

2.7 Residual hazards due to the heat carrier glycol

⚠ WARNING

Danger of injuries and damage to property!

General description of hazards:

The unit is operated as standard with a heat carrier (water/glycol mixture – for example, ethylene glycol; synonyms: ethane-1,2-diol, glycol). Prior agreement with the manufacturer is imperative when using other heat carriers.

Ethylene glycol is a colourless, slightly viscous, not very fluid, water-mixable, deliquescent liquid with a sweet smell or taste.

Unauthorised people must not have access to the unit. When setting up it must be ensured that heat carrier escaping from the unit cannot penetrate the interior of the building or put people at risk in any other way.

⚠ WARNING

When setting up it must be ensured that heat carrier escaping from the unit cannot enter water or waste water systems.

Danger of environmental pollution!

Ensure that no heat carrier enters water or waste water systems.

⚠ WARNING

Danger of harm to health!

With skin contact ethylene glycol causes slight irritation with the danger of skin absorption; with eye contact mucous membrane irritation; with ingestion agitation with disruption of the central nervous system; with prolonged endangering effect – fatigue, coordination disruption, unconsciousness, kidney damage.

- Avoid contact with skin, eyes and clothing! Remove contaminated, soaked clothing immediately!
- Ethylene glycol vapours are heavier than air and may flow off to rooms on a lower level. In still air there may be an increase of the ground level concentration. With high concentrations, there is a danger of suffocation due to reduced oxygen concentration, especially at ground level.
- To avoid the inhalation of high vapour concentrations, the working rooms must be well aired.
- Test the tightness of the unit regularly, as specified in these instructions.



Ignition and fire hazard!

Ethylene glycol is flammable and explosive at higher temperatures in a vapour/gaseous state.



- Keep ethylene glycol away from ignition sources.

• Suitable fire fighting equipment must be provided on site when working with flames, such as grinding or soldering, for example.

• Ensure that the provided fire fighting equipment is provided in sufficient quantities, that it functions properly and that the extinguishing agent does not react with the heat carrier.

- No smoking!



Danger of poisoning!

Contact of the heat carrier with open fire must be avoided, as toxic combustion products can form.

- Prevent heat carrier contact with open fire.

• Only perform welding and soldering work after completely draining the heat carrier from the relevant section of the unit. Ensure good ventilation.



• Do not allow contact with powerful oxidation agents (chromo-sulphuric acid, potassium permanganate, fuming sulphuric acid, or similar)! Danger of strong reactions!



Frostbite hazard!

With insufficient frost protection filling and operation in areas with frost hazard the unit can cause frostbite. With units that cannot be drained completely the hazard of frostbite also remains after draining.

- It is imperative that the proper ventilation be ensured when draining the unit.

• With pressure test, operation and shutdown of units filled with water or insufficient frost protection filling or insufficient setting of the heat carrier, these are disrupted at minus temperatures.

2.8 Residual hazards caused by vibrations

⚠ WARNING

Danger of injuries and damage to property caused by escaping materials

If fans are damaged during fan operation, flying parts of the fan blades can injure people or cause damage to property close to the fan.

Fans, components and cables in the system including the heat carrier circuit must be designed, constructed and integrated so that dangers caused by vibrations that it or other parts of the system generate are reduced to an absolute minimum, while incorporating all available means for reducing vibrations, preferably at the source.

NOTICE

Damage to property caused by vibrations

Vibrations that are increased by imbalances, as created by dirt or fan blade damage, are regularly caused with fan operation. The vibrations are transferred to the unit, where they can cause damage and damage the unit mounting or heat carrier circuit components connected to the unit.

Check the fan blades and protection grilles regularly for dirt and the fans for quiet running (see "Fans", page 64).

2.9 Residual hazards caused by pressurised parts

⚠ WARNING

Injury and damage to property caused by pressurised components that contain heat carrier.

Breaks in pressurised pipes or pressurised components of the unit can cause injuries or damage to property caused by escaping materials. A sudden large release of the working fluid with its hazardous properties after a break or leak on pressurised components of the unit can cause the following hazards:

- Irritations and health hazards
- Strong chemical reactivity
- Flammability
- Suffocation
- Panic,
- Environmental pollution

Ensure that the unit in question is pressure-free before maintenance work begins or remove the working fluid from the unit in question.

Perform maintenance work – especially soldering – on the unit in question only after completely removing the working fluid from the unit.

2.10 Residual hazards caused by defective installation

WARNING

Injuries and damage to property caused by defective installation!

Defective installation results in hazards caused by:

- Break or leak on liquid-carrying unit components and pipes
- Uneven load distribution on the fixtures with the danger of stresses within the unit or unit displacement (breaks or leaks on fluid-carrying components of the unit and pipes; danger of breaking off).
- Insufficient securing of working fluid-carrying lines against mechanical damage! On-site connections: loaded installation; effect of forces on the distribution and header pipes with the danger of breaks or leaks on fluid-carrying components of the unit and pipes; danger of breaking off!
- Break-off danger of the unit with hazard of escaping working fluid and exposed electrical cables.
- Danger of damage caused by environment-conditional hazard sources (production, transport and other processes at the set-up point).
- Unit functional faults caused by air inlet/outlet obstructions.
- Obstruction of all-side inspection, checks and maintenance, i.e. no unobstructed accessibility to the working fluid-carrying and electrical components, connections and cables, no recognisable identifiers on the pipes and insufficient space for tests.

Ensure that:

- The units are to be installed on the fixing points corresponding with their weights and tightened with fixing bolts. The operator or installer is responsible for ensuring that the bolted connections are of an adequate strength.
- The diameters of the mounting holes have been statically determined by the manufacturer and the fixing bolts are adapted accordingly.
- The fixing bolts are secured against loosening by means of an appropriate locking device.
- The fixing bolts are not overtightened or stripped.
- All fixing bolts are tightened equally to achieve a load distribution on the connections that is as balanced as possible.
- All fixing points maintain the same spacing to the fixing level permanently and under load, so that no mechanical stress occurs in the unit structure. The units are anchored in their fixing position in order to prevent the equipment from moving.
- The functional safety of the fixing bolts is tested as part of the maintenance periods. see "Maintenance", page 62,
- The unit is fixed and set up so that it is not damaged by environment-conditional hazard sources (production, transport and other processes at the set-up point) or its functioning is not disturbed by the interventions of unauthorised persons.
- The units are fixed and set up so that unobstructed air inlet/outlet is constantly available without any air short circuiting.
- The units are fixed so that they can be inspected, checked and maintained from all sides at all times, i.e. there must be unobstructed access to the refrigerant-carrying and electrical components, connections and lines, the pipeline labelling must be identifiable and adequate space must be available for testing.
- The working fluid-carrying lines must be protected against mechanical damage. On-site connections: when installing keep the unit free of load; force must not be exerted on the distribution and header pipes.

- The following must be observed without fail when installing the unit:
 - Imperative adherence to spacing from objects that could be endangered or heat carrier effects.
 - Easily flammable materials must not be placed below the unit.
 - Set up and fix units as follows: In areas that are used for inner-plant traffic, the pipelines to and from the unit must be installed only with connections and fittings that cannot be removed.
 - Release devices to prevent liquid escapes must be provided and available.
 - Subcooled liquid may be present in only the lowest possible amount in system sections in shutdown state – minimized number of “fluid sacks”.

2.11 Residual hazards with break during operation

WARNING

Injuries and damage to property caused by break during operation!

- Incorrect installation (see "Residual hazards caused by defective installation", page 31),
- Non-compliance with maximum permissible operating pressure (see "Operating conditions", page 22),
- Disregarding pressurised line sections with maintenance (see "Residual hazards caused by pressurised parts", page 30),
- Disregarding residual hazards caused by vibrations (see "Residual hazards caused by vibrations", page 30)

result in ruptures during operation and maintenance. This results in dangers caused by

- escaping materials (see "Residual hazards caused by pressurised parts", page 30),
- released working fluid (see "Residual hazards due to the heat carrier glycol", page 28)

Ensure that:

- The installation is fault-free.
- The maximum permissible operating pressure is always adhered to.
- Pressurised line sections are de-pressurised before all maintenance and repair work.
- Vibrations from the refrigeration system including the heat carrier circuit, (vibrations caused by the complete system's compressors, components and lines, including the heat carrier circuit) and from the fan (imbalances caused by frost, ice, accumulations of dirt or damage) are reduced with all available means and brought down to an absolute minimum.
- Release devices to prevent liquid escapes are provided and available.

2.12 Residual hazards caused by escaping objects or liquids

⚠ WARNING

Injuries and damage to property caused by escaping objects or liquids!

Residual hazards caused by escaping objects and liquids (see "Residual hazards with break during operation", page 32).

2.13 Residual hazards with disposal

⚠ WARNING

Danger of injuries and damage to property caused by working fluid glycol!

The following notes are recommendations for the proper professional disposal of the unit. Applicable waste disposal laws are binding for the country of operation:

- Disposal must only be carried out by experts.
- All unit components, e.g. working fluids, heat carrier, heat exchangers, fans, must be disposed of properly as specified.
- Used working fluid that is not determined for reuse, must be treated as waste and safely disposed of. There must be no emissions into the environment.
- A disposable single-use container must not be used, as heat carriers escape during disposal.
- The working liquid receiver must not be overfilled. The maximum permissible pressure of the working fluid container must not be exceeded during the work process.
- The working liquid receiver must not be overfilled. The maximum permissible pressure of the working fluid container must not be exceeded during the work process.
- The working fluid must not be filled in a liquid container that contains another or an unknown working fluid. This other or unknown working fluid must not be released into the atmosphere, but rather identified, treated again, or properly disposed of as specified.
- An officially authorised facility can be used for destroying the working fluid.
- It must be ensured that all unit components containing heat carriers are disposed of properly as specified.
- The unit consists predominantly of the basic materials copper, aluminium, galvanized steel (casings), and steel, aluminium, copper, polyamide (electrical components). These materials can be handled by the waste industry, even in paint-treated state, and recycled via mechanical and thermal separation.
- Before scrapping the working fluid-carrying unit components must be drained, whereby the pressure must be reduced to at least 0.6 bar absolute for a unit pipe volume up to and including 200 l, and to 0.3 bar absolute for a unit pipe volume over 200 l. The pressure reduction process is then ended when the pressure no longer increases and remains constant, and the unit is at ambient temperature.

⚠ WARNING

Danger of environmental pollution!

Ensure that no heat carrier enters water systems or sewage.

Operate the facility for recovering or disposing of working fluids so that the danger of a working fluid emission into the environment is kept as low as possible.

- Operate the facility for recovering or disposing of working fluids so that the danger of a working fluid emission into the environment is kept as low as possible.

Güntner GmbH & Co. KG's transport packaging is made from environmentally compatible material and is suitable for recycling.

3 Technical data

3.1 Heat exchanger (typical values)

NOTICE

The typical values given here refer to standard types of this series. The following is valid especially for special equipment: Please observe the data in the calculation (Annex) and on the nameplate.

NOTICE

The fans' capacity values depend on the ambient temperature and on the air resistance at the set-up point.
All electrical parts must be installed in accordance with EN standards.

Project number	See order-related documents
Unit name	See order-related documents
Manufacturer number	See order-related documents
Production year	See order-related documents
Heat carriers	See order-related documents
Volume	See order-related documents
Maximum permissible pressure (PS)	0 - 10 bar
Permissible air humidity	> 100%
Test date	See order-related documents
Test medium	Dry air
Airborne noise emitted	See order-related documents In accordance with the standard procedure for calculating sound level described in EN 13487; Annex C (normative).
Weight	See order-related documents

3.2 Fans

230 V 1~ 50 Hz is switched in alternating current for GFV fans used with 450 to 650 mm diameter. The fans with 800 to 1000 mm diameter can be speed-controlled with Güntner control units. The alternating current fans can generally be operated with 2 different speeds by D-S changeover. 5 capacity/sound levels (N, M, L, S, E) can be delivered.

Fan type	See order-related documents
Protection rating	IP 54, thermal class 155 and DIN VDE 0530

Current type	Rotating or alternating current
Voltage	400 V 3~ 50 Hz or 230 V 1~ 50 Hz
Balancing quality	Q 6.3 in acc. with VDI 2060
Permissible air temperature	Operating range: at least -30°C to +55 °C
Protective devices	<ul style="list-style-type: none">• Thermal: Thermo-contacts (temperature monitor for safeguarding against thermal overload).• Mechanical: Protective contact grille in acc. with EN 294

4 Set-up and function

The drycooler consists of,

- a heat exchanger, consisting of pipe coils fitted with fins (copper pipe, aluminium fin), distribution pipes and header outlets (copper) and pipe connections to the pipe system,
- and – depending on the version – with one or more low noise axial fans with maintenance-free motors.

Dry coolers of the GFV series are intended for installation in the heat carrier circuit of a refrigeration system. The refrigeration system is a combination of working fluid-carrying components and fittings connected with one another, which form a closed circuit, in which the working fluid circulates.

The heat carrier is the working fluid that is used for the heat exchange, and which remains in the liquid phase during the heat absorption.

The liquid used is a heat carrier in acc. with EN 378-1, para. 3.7.2. There is no imminent danger for the staff.

The heat carrier absorbs heat at a low temperature, heats up, and gives the heat off again at a higher temperature. The dry cooler cools the heat carrier by giving off heat to the air (air-side) that is being moved by fans over the dry heat exchanger surface.

Fan motor

The fan motors for the 450 mm to 650 mm diameter fans are connected to AC, 230 V 1~ 50 Hz.

The fan motors for the fan diameters 800 mm to 1000 mm run on three-phase electricity. A "star connection" can be used to reduce the speed if required. The star connection / star = low voltage (S) or delta connection / delta = high voltage (D) must be adjusted to the actual on-site mains voltage.

The AC fan motors can be speed-controlled with Güntner control units. The direction must be checked; if the direction is wrong, it can be changed by interchanging two phases.

Water spray system (optional)

The system can be extended with optional water spraying for relieving capacity peaks. Water spraying can, however, be used only subject to restrictions (max. 50 hours a year). A corresponding pipe system with nozzles is available.

5 Fan motor

NOTICE

During longer periods of storage or standstill, the fans must be activated during 2 to 4 hours per month.

NOTICE

For fans with the protection rating IP55 or higher, existing closed condensation water holes must be opened at least once every six months.

AC technology

The AC motors are protected against overheating by a thermocontact (or PTC resistor).

For motors with a thermocontact, the thermocontact must be switched in such a way that the motor cannot be powered on when the thermocontact is triggered. A locking mechanism is recommended to prevent unintentional renewed power-on.

Motors with a PTC resistor need an additional external trigger unit for the installed thermistors. A locking mechanism is recommended to prevent unintentional renewed power-on. The test voltage at the thermistors is not permitted to exceed 2.5 V or only current-limiting test devices are allowed to be used.

When using a star-delta connection, a corresponding delay must be considered.

For motors with direct starting and a connection value > 4.0 kW, an inrush current limitation (soft start using a thyristor) could be required.

If frequency converters are to be used for speed control, the following points must be considered for external rotor fans:

Between the frequency converter and fans, all-pole sine-wave filters must always be installed (sine wave-shaped output voltage; filter effect between phase to phase and phase to earth).

All Güntner frequency converters are equipped with this function as standard. Conventional three-phase motors are suitable for direct operation with frequency converters.

Three-phase fan motors can be operated with a star-delta connection or with speed control. The direction of rotation must be checked. A change in the direction of rotation, if it is wrong, is made by interchanging two phases.

EC technology

NOTICE

The fan motors have their own electronic power component. This power component is controlled by means of Güntner Motor Management (GMM). The motors can be operated using single-phase (1~, 200 - 277 V AC, 50/60 Hz) or three-phase (3~, 380 - 480 V AC, 50/60 Hz) voltage rates, depending on type. When operated without GMM, the fans should be controlled with a voltage of 0 - 10 V. Refer to the connection plans or the information on the motor terminal box for details on the electrical connection.

6 Transportation and storage

6.1 Safety

⚠ WARNING

Crushing danger with falling down!

The unit weighs between 70 kg and 290 kg. It can slip and fall off the transporting device, causing serious injuries or death. Heavy impacts or vibrations can damage the unit.

Ensure that the assigned staff is trained for proper unloading.

Ensure that nobody is under the unit or near the loaded area during the transport.

Ensure even weight distribution. Observe the transport label on the packed unit (see "Other signs and notes on the unit or packaging", page 18).

Crane and forklift transport: Ensure that there is no snow on the unit and no wind.

Secure the unit against slipping and mechanical damage.

When transporting by crane: The hooks and shackles of the load lifting equipment must be only attached at the points specified by the manufacturer, i.e. at the factory mounted crane lugs. Ensure that the unit casing is not crushed by slings.

Use auxiliary transport equipment where required. Use a transporting device appropriate for the unit's weight(see graphic in chapter "Transportation and storage"). You will find the weight of the unit in the order-related documents (see "Set-up and other applicable documents", page 8). Do not use connection pieces and outlet headers as attachment points for lifting, pulling, fixing or mounting. This can cause leaks.

Transport the unit carefully. Particularly avoid setting the unit down hard.

6.2 Transportation and storage

NOTICE

Read and observe all transport signs on the units' packaging!

Prolonged mechanical stresses caused by uneven road surfaces and potholes and vibrations during transport by ship can cause transportation damage. Before transportation by sea or in countries with difficult transport routes, attachment parts that are likely to vibrate – in particular fans and base stands – must be removed for transportation.

- ▶ Use suitable equipment to transport the packed unit to the destination installation site (for example, a crane or fork-lift).
- ▶ Unload the unit.

⚠ WARNING

Danger of damage to goods by falling when transporting by fork-lift!

Packed units that are not lifted with forks of appropriate length could slip and fall.

Only lift the packed unit with a fork-lift with full fork length. Be careful to comply with the positioning specifications for the fork-lift.

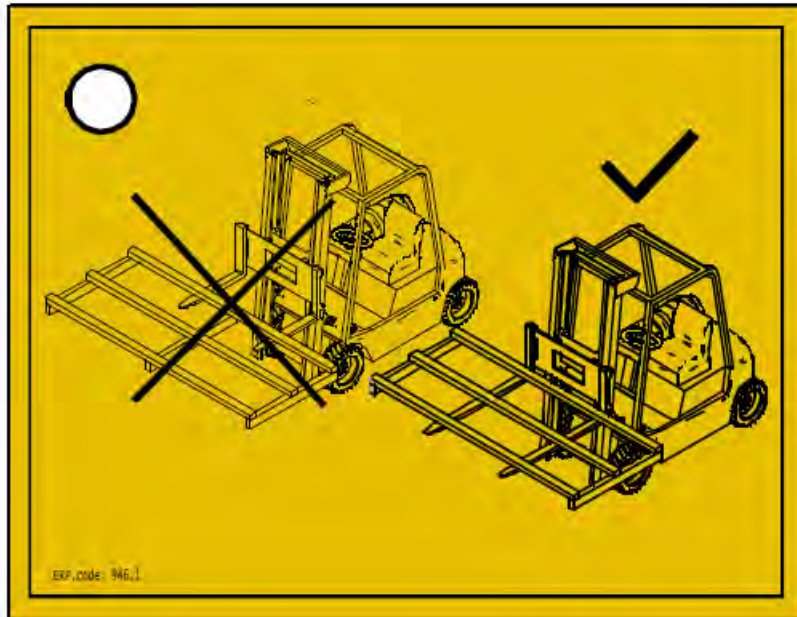

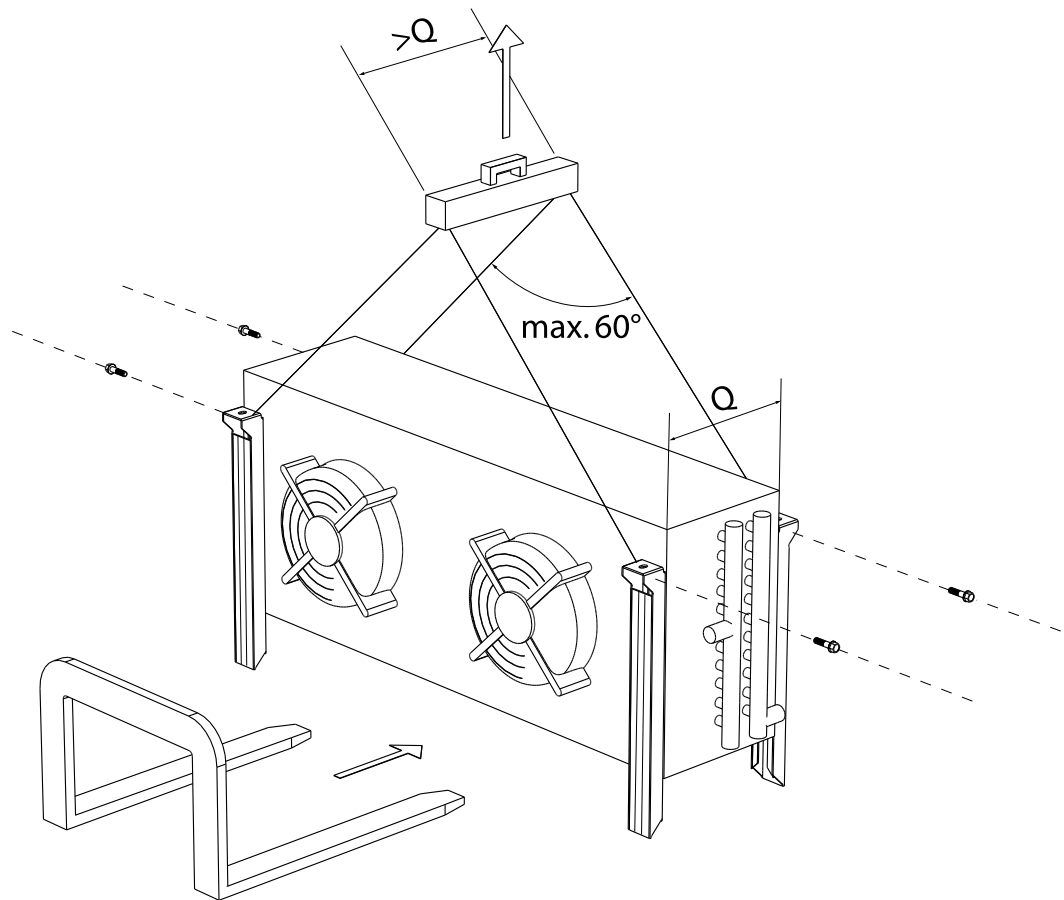

6.3 Storage before installation

NOTICE

Danger of corrosion and dirt build-up!

Moisture and dirt must be prevented from entering the unit.

- ▶ Protect the unit against dust, dirt, moisture and wetness, damage and other harmful effects. Harmful effects: see "Safety instructions for set-up and start-up", page 42
- ▶ Do not store the unit for longer than necessary. Only store the units in their original packaging until installation. Always only place packaging units of the same size on top of one another.
- ▶ Store the unit at a protected place free of dust, dirt, moisture and damage-free until its set-up (well-ventilated halls or roofed storage site).
- ▶ If the unit set-up is delayed with regard to the planned installation time: protect the unit against weather and other harmful effects and dirt and other contaminants with an appropriate cover. The unit must also be well-ventilated here.

7 Set-up and start-up

7.1 Safety

7.1.1 Safety instructions for set-up and start-up

⚠ WARNING

Danger of injuries and damage to property with escaping heat carrier!

Incorrect installation causes the danger of working fluid escaping when the unit is operated and injuries or damage to property (see "Residual hazards due to the heat carrier glycol", page 28)

Follow the set-up instructions in this chapter precisely and apply extreme care!

NOTICE

Danger of damage to the system!

Foreign materials and contaminants in the working fluid circuit can impair the effectiveness or damage system components. Particularly harmful contaminants are:

- Moisture
- Atmospheric air
- Soldering residues
- Rust
- Soot/ash/cinders
- Metal cuttings
- Dust and dirt of all kinds

Moisture in the working fluid-carrying components of the unit can have the following consequences:

- Acidification
- Ageing and heat carrier decay
- Corrosion
- Changing the prescribed concentration of heat carrier corresponds to an increased danger of too little frost protection in the dry cooler, which could result in the unit being destroyed when subjected to minus temperatures.

Atmospheric air and other non-condensable gases can have the following consequences:

- Oxidation of the heat carrier
- Chemical reactions of the heat carrier
- Changing the concentration of heat carrier corresponds to an increased danger of too little frost protection in the dry cooler, which could result in the unit being destroyed when subjected to minus temperatures.

Heat carrier chemical reactions in the presence of moisture or atmospheric air with ageing and decay can have the following consequences:

- Formation of organic and inorganic acids
- Corrosion

Other contaminants can cause:

- Accelerated chemical processes (decomposition)
- Mechanical and electrical faults in the heat carrier circuit.

During the installation (connecting the working fluid-carrying components of the unit to the working fluid-carrying system of the installation's or to the refrigeration system's heat carrier circuit) ensure that internal contamination is strictly avoided.

Perform the installation with extreme cleanliness.

Finish all on-site pipe installation work before releasing the transport pressure!

Only release the transport pressure immediately before installation.

Only remove the sealing caps on the distribution and header pipe immediately before installation.

NOTICE

Danger of corrosion and dirt build-up!

Moisture and dirt must be prevented from penetrating the unit. If moisture and dirt penetrate the unit there is also the risk of damage to fittings and other components .

Protect the unit against dust, contamination, moisture and wetness, damage and other harmful influences. Harmful influences are, for example:

- Mechanical: Damages caused by impacts, objects falling on or against, collisions with transport equipment, etc.
- Physical: Damages caused by close by concentrated flammable gases
- Chemical: Damages caused by contaminated atmospheres (salt, acid, chlorine, sulphur-containing, or similar)
- Thermal: Damages caused by close-by heat sources

Begin with the installation as soon as possible.

⚠ WARNING

The electrical installation may be performed only by electricians (or by expert technicians with appropriate qualifications) in compliance with the relevant VDE rules (or applicable national and international regulations) and the TCC of the EPCs!



7.1.2 System-side safety requirements

The unit is a component of the heat carrier circuit system and can only be operated in conjunction with the system .

- All equipment required for operating the unit must be integrated into the switching and activation equipment (complete system) :
 - Electrics: Fans and other electrical components
 - Working fluids: valves and fittings
- The heat carrier-side and electrical connections for the unit must be available for the unit on the heat carrier circuit of the refrigeration system. The connections must be specified in the order-related offer documents.
- The power supply of the fans must be provided in acc. with the specifications on the type plate on the fan motors.
- A switch-off device for preventing unexpected start-up (repairs switch), which separates all active conductors from the power supply (all-pole switch-off), must be provided for the fans in acc. with EN 60204-1.
- The fans' switch-on/off device must be secured (e.g. with a padlock) to prevent uncontrolled fan start-up.
- The electrical motor, repairs switch, terminal box and switching cabinet connections must be provided in acc. with the respective connection diagrams.
- It must be possible to shut off the unit if a leak occurs.
- People wearing ambient air-independent breathing apparatus in full protective clothing must also be able to activate all safety-relevant shut-off fittings.
- It must be possible to activate all devices meant for diverting escaping working fluids from a safe position.

7.1.3 Customer-side safety precautions

⚠ WARNING

Danger of injuries!
 The unit contains heat carrier(see "Residual hazards due to the heat carrier glycol", page 28).
 The unit is operated as standard with the heat carrier ethylene glycol (synonyms: ethane-1,2-diol, glycol). Prior agreement with the manufacturer is imperative when using other coolants.
 Ethylene glycol is a colourless, slightly viscous, not very fluid, water-mixable, deliquescent liquid with a sweet smell or taste.
 With skin contact ethylene glycol causes slight irritation with the danger of skin absorption; with eye contact mucous membrane irritation; with ingestion agitation with disruption of the central nervous system; with prolonged endangering effect – fatigue, coordination disruption, unconsciousness, kidney damage.

Ignition and fire hazard! Ethylene glycol is flammable and explosive at higher temperatures in a vapour/gaseous state. Keep ethylene glycol away from ignition sources. No smoking!
 Ethylene glycol vapours are heavier than air and may flow off to rooms on a lower level. In still air there may be an increase of the ground level concentration. With high concentrations, there is a danger of suffocation due to reduced oxygen concentration, especially at ground level.
 Avoid contact with skin, eyes and clothing! Remove contaminated, soaked clothing immediately!
 There is no imminent danger for the staff.
 Do allow contact with heavy oxidation agents (chromic-sulphuric acid, potassium permanganate, smoking sulphuric acid, or similar)! Danger of strong reactions!
 Unauthorised people must not have access to the unit. When setting the unit up it must be ensured that the coolant escaping from the unit cannot penetrate the interior of the building or put people at risk in any other way.
 Comply with the requirements of EN 378-3 for coolants, filling weight and cold transfer systems.
 Only install the unit in accordance with EN 378-1 in the commissioned configuration and only in a set-up room that the unit manufacturer has configured the unit for.
 Install the unit in accordance with EN 378-3, section 5 in a special machine room if a coolant concentration of more than that specified in EN 378-3 could endanger the work environment. Take effective protective precautions if such a spatial separation were to be required, but is not possible.
 Install the electrical equipment (for fan operation, for ventilation, for lighting and for the alarm system) in the set-up room while observing the condensing-out of moisture and drip water formation, as well as the risk level of the coolant in accordance with EN 378-3; section 6.
 Arrange alarm systems to warn about explosion or fire dangers or ammonia concentrations that are hazardous to health and for control purposes in the unit set-up room in accordance with EN 378-3; section 7.
 Ensure that the device in the set-up room is not exposed to any inadmissible high temperature effects. Effectively protect the unit against heat sources or temporary high temperatures.

⚠ WARNING

Danger of environmental pollution!

- Set up the unit so that heat carrier, which can escape from the unit in the event of a fault, cannot enter water systems or sewage.
- Operate the facility for recovering or disposing of heat carrier so that the danger of a heat carrier emission into the environment is kept as low as possible.

7.2 Requirements as regards the place of installation

You will find the dimensions and weights in the order-related documents.

- ▶ Ensure that the unit is set up so that it is not damaged by environmental hazard sources (production, transport and other processes at the set-up point) and its functioning is not disturbed by the interventions of unauthorised persons.
- ▶ Position the unit so that it cannot be damaged by internal traffic or transport processes.
- ▶ Enable optimum unit control and accessibility:
 - Place the unit so that it can be monitored and controlled from all sides at all times.
 - Ensure that sufficient space is provided for maintenance.
 - Ensure that all fluid-carrying components, connections and lines and all electrical connections and lines are easy to access.
 - Ensure that the tubes' identification is well visible.

Several units can be placed space-savily in rows with high nominal capacity to cover high capacities. With double or multiple row set-ups a substructure is required to guarantee sufficient air-side pressurising.

NOTICE

Danger of rusting of the vibration dampers or unit feet.

Installation of the unit in stagnant water or on surfaces on which water can collect (such as glycol protectors) can lead to rust on vibration dampers and unit feet.

Rusting vibration dampers or unit feet cause instability of the unit.

Outdoor set-up while allowing for main wind direction

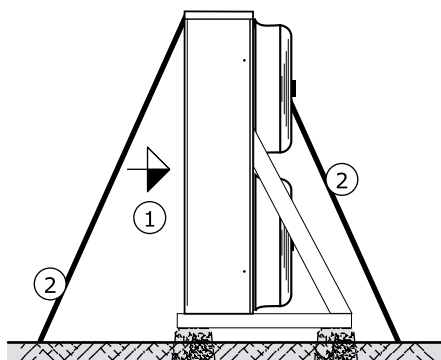

- 1 Air-flow direction
- 2 Bracing

Note: With two-row units cable bracing in accordance with Güntner standard 03.02.02 is required.

Set-up on a console or on a support

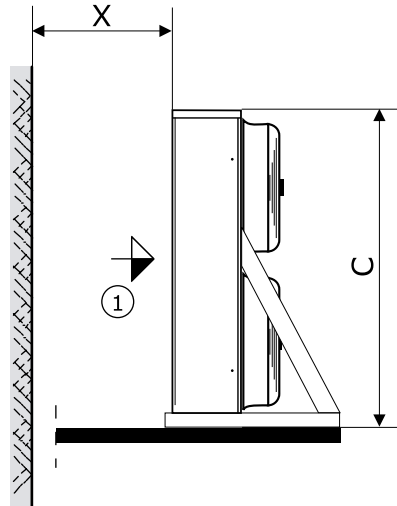

1

Air-flow direction

Lateral spacing $Y \geq 400$ mm

Min. spacing X:

- With single-row units: $X \geq 0.5 * C$
- With two-row units: $X \geq 0.35 * C$

Note:

A wall is only allowed on one side

Airflow from below

7.3 Unpacking the unit

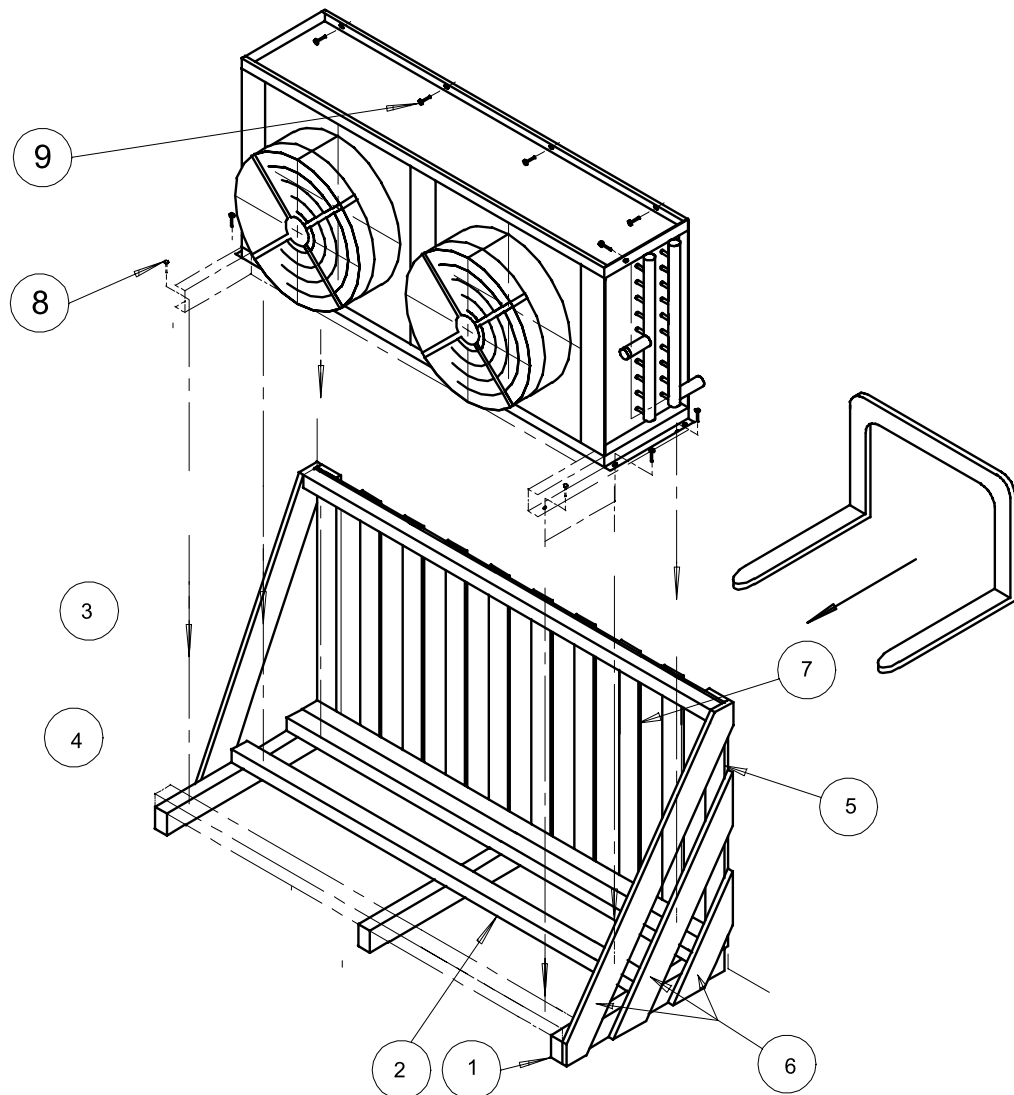

- ▶ Remove bolts (8 and 9).
- ▶ Remove unit from transport frame (timbers 1, 2, 3 and form boards 4, 5, 6, 7).
- ▶ Check that no parts are missing. You will find a list of the contents of the package in the order-related documents.
- ▶ Any transport damage and/or missing parts must be recorded on the delivery note. The facts must be immediately reported to the manufacturer in writing. Damaged fins can be straightened on-site with a fin comb.
- ▶ Check the transport excess pressure: The units are delivered from the manufacturer with approx. 1 bar transport excess pressure (cleaned and dried air). Check the transport pressure at the Schrader valve (pressure measurement). If the unit is unpressurised: Report this to the manufacturer immediately and make a note on the delivery note An unpressurised unit indicates a leak on the unit!

CAUTION! Danger of injuries and damage to property with escaping heat carrier! An unpressurised unit indicates a leak due to transport damage. Escaping heat carrier through leaks on the unit can cause injuries (see "Residual hazards due to the heat carrier glycol", page 28). Do not put the unit into operation!

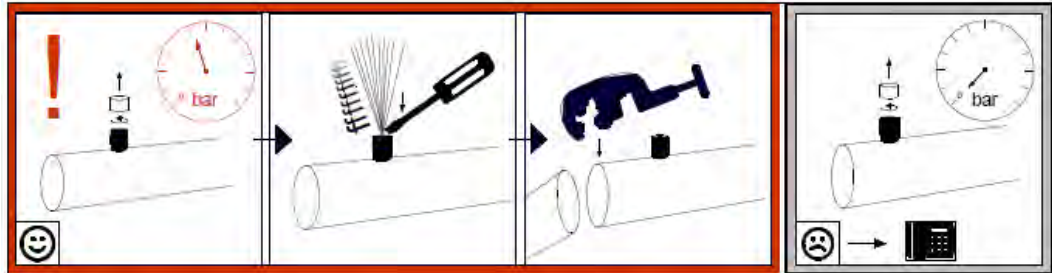

- 1 Screw off the cap.
- 2 Check the transport excess pressure: The units are supplied from the factory with transport excess pressure (cleaned and dried air). Release the transport pressure using the valve prior to installation. If the unit is unpressurised: Report this to the manufacturer immediately and make a note on the delivery note

NOTICE

Risk of corrosion and contamination!

Moisture and dirt must be prevented from penetrating the unit.

Protect the unit against dust, dirt, moisture and wetness, damage and other harmful effects. Harmful effects: see "Safety instructions for set-up and start-up", page 42

Begin with the installation as soon as possible.

7.4 Installation

7.4.1 System-side requirements for stress-free installation

- ▶ Prevent stresses in the unit:
 - Ensure that all fixing points have the same spacing to the fixing level.
 - Ensure that all fixing points maintain the same spacing to the fixing level under load and permanently.
- ▶ Set up and fix units as follows: Airflow must not be impaired by obstructions.
- ▶ The units must be installed on fixing points that are appropriate for the unit's weight and then bolted with fixing bolts. The operator or installer of the equipment is responsible for ensuring that the bolted connections are of an adequate strength. The following instructions must be observed when fixing the units:
 - The diameter of the mounting holes have been statically determined by the manufacturer; the fixing bolts must be adapted accordingly. When calculating the transferring bearing strength it is imperative to take into account the total weight of the unit (= structural weight + weight of pipe content + additional weight, such as water, frost, ice, dirt or similar).
 - The fixing bolts must be secured against loosening with an appropriate locking device.
 - The fixing bolts must not be overtightened or stripped.
 - All fixing bolts must be tightened equally.

- ▶ Prevent the unit from shifting in its position. Fix the unit in its position. Tighten the fixing bolts and secure then against loosening.
- ▶ Only fix the unit to the intended fixing points.

7.4.2 Mounting the vibration dampers (optional)

The optional vibration dampers are separately enclosed with the unit.



M8	-->	25Nm	
M12	-->	80Nm	
M16	-->	206Nm	
M20	-->	415Nm	

8.8

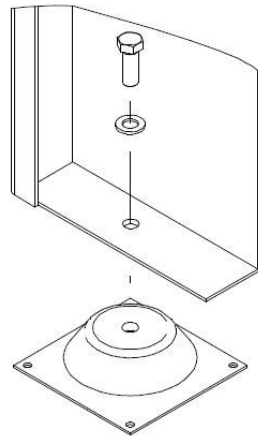

- ▶ Check that the list of package contents is complete.

Observe the specified torque.

- ▶ Assemble the individual parts in the order shown.

Type I

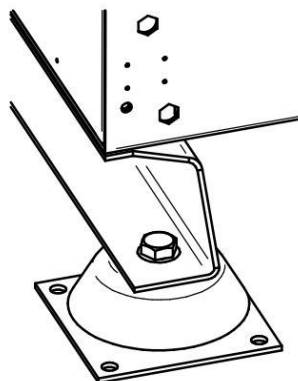

Pre-mounted vibration dampers

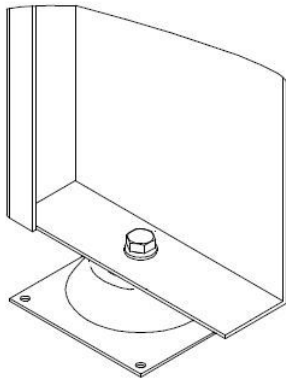

Type I

7.5 Notes on connecting the unit

⚠ WARNING

Danger of injuries and damage to property with escaping heat carrier!

Incorrect installation causes the danger of working fluid escaping when the unit is operated which can result in injuries or damage to property (see "Residual hazards due to the heat carrier glycol", page 28).

Prevent working fluid from escaping from the unit into the environment.

- Secure all working fluid-carrying lines against mechanical damage.
- In areas that are used for internal traffic, only lay the pipelines to and from the unit with connections and fittings that cannot be removed.

Ensure that the on-site connections do not exercise any forces upon the distribution and header points. This can cause leaks on the working fluid connection points of the unit and on connection points of the on-site pipe-laying.

Ensure that:

- Release devices to prevent liquid escapes are provided and available.

7.5.1 Connect the unit to the heat carrier circuit of the system

⚠ WARNING

Danger of injuries and damage to property!

Improper connection to the heat carrier circuit of the system causes hazards:

- Leaks result in escaping heat carrier (see "Residual hazards due to the heat carrier glycol", page 28).
- Soldering and welding work on pressurised parts can result in fires or explosions.
- Smoking or open light can cause fires or explosions.
- Ensure that stresses and vibrations from the system including the heat carrier circuit are not transferred to the unit.
- Only lay working fluid-side connections stress-free! The on-site pipeline system must be braced before connecting to the unit!
- Soldering and welding work is only permitted on unpressurised units!
- Evacuate the unit professionally in acc. with EN 378-2.
- The use of open fire at the installation site is forbidden. Fire extinguishers and extinguishing agents used to protect the equipment and the operating staff must comply with the requirements of EN 378-3.

- ▶ Install the pipes in acc. with EN 378-1 and EN 378-3. Ensure here:
 - Release devices to prevent liquid escapes must be provided and available.
 - Avoid transmitting vibrations to the unit via conduits or pipes. If necessary, use vibration dampers.
 - Route the return line with a continuous gradient of from 3 to 5° along the direction of flow. Make sure it can drain freely into the expansion tank!
 - Always lay fluid supply and return lines separately from one another.
 - The free space around the unit must be big enough to ensure there is no danger to the unit; regular maintenance of the components must be possible, and it must also be possible to check and repair components, pipes and fittings.
 - It must be possible to shut off the unit if a leak occurs. It must be possible to activate all devices used for diverting escaping working fluids from a safe position.
 - Electrical systems (e.g. for fan operation, for ventilation, for lighting and for the alarm system) must be installed in acc. with EN 378-3; section 6 at the set-up location while observing humidity condensation and drip water formation.
 - Observe the following when soldering:
 - All connections must be hard-soldered!
 - Avoid percussive soldering joints; use copper pipe ends that are widened on one side (capillary soldering)!
 - Prevent leaks, solder precisely and carefully!
 - Prevent overheating when soldering (danger of excessive scaling)!
 - Use shielding gas when soldering (prevent excessive scaling)!
- ▶ After completing pipe installation and before connecting the units they must be professionally cleaned internally and evacuated in acc. with EN 378-2.

7.5.2 Unit electrical connection and protection

All fans with rotating current drive can be operated via D-S switch-over with two different speeds:

- D: high speed
- S: lower speed

The fans can be speed-controlled with the use of Güntner control units.

- ▶ Connect fan motors in acc. with motor connection wiring diagram in the motor terminal box or circuit diagram and check connection.
- ▶ Provide power supply in acc. with the specifications on the fan motor's type plate or circuit diagram:
 - The fan motors are operated in 1~ alternating current and 3~ rotating current (IP 54).
- ▶ Protection of fan motors required: Connect thermocontacts for the motor protection and evaluate them, if available.
- ▶ Provide and secure all electrical lines to the connection boxes/switch cabinets acc. to EN 60204-1. Ensure compliance with the IP protection class. Observe the information in the circuit diagram. The protection class is specified in the chapter "Technical data - fans".

⚠ WARNING

Risk of damage to property! If the fuse rating is too high there is the risk of injuries to people and damage to property.

7.6 Perform acceptance test

⚠ WARNING

Danger of injuries and damage to property!

Escaping heat carrier can cause injuries (see "Residual hazards due to the heat carrier glycol", page 28).

Perform the following acceptance test with an expert before starting up the unit after making important changes and after a unit exchange.

- ▶ Ensure that the temperature and air humidity at the installation site are in line with the technical data (see "Technical data", page 35).
- ▶ Ensure that sufficient air can be sucked in and released.
- ▶ Ensure that the supply feed is sufficient for the required energy. Compare the unit inside the heat carrier circuit of the system with the plans of the system including the heat carrier circuit and the electrical wiring diagrams.
- ▶ Test the unit for vibrations and movements that can be caused by the fans and operation of the system including the heat carrier circuit. Remove oscillations, vibrations and movements following consultation with the manufacturer or independently.
- ▶ Perform visual inspection of the structural design, the brackets and fixtures (materials, sequence, connections), the ability to operate and the arrangement of the fittings.
- ▶ Check and if necessary re-tighten all threaded connections, especially on the fans.
- ▶ Check installation of pipe connections.
- ▶ Check laying of working fluid-carrying connection pipes.
- ▶ Ensure that the unit is protected against mechanical damage.
- ▶ Ensure that the unit is protected against inadmissible heating up and cooling down.
- ▶ Check the fan blades protection.
- ▶ Ensure that optimum unit control and accessibility are guaranteed.
 - Is the unit placed so that it can be monitored and controlled from all sides at all times?
 - Is sufficient space provided for maintenance?

- Are all working liquid-carrying components, connections and lines and all electrical connections and lines easy to access?
- Are the tube identifications well visible?
- ▶ Check heat exchanger surfaces for dirt and clean as required (see "Clean unit", page 66).
- ▶ Perform function tests on the fans (rotation direction, power consumption, etc.).
- ▶ Check electrical connections of the fan motors for damage.
- ▶ Check the quality of the soldering connections, the electrical connections and the fixture connections.
- ▶ Perform pressure test with test gas and with a test pressure of 1.1-times the permissible operating pressure: check the connection seals and detect leaks, e.g. with foaming agent, or similar.
- ▶ Check corrosion protection: Perform a visual inspection on all return bends, components and component holders that are not heat-insulated. Document and archive test results.
- ▶ Perform test run. Observe and check unit during test run, in particular for:
 - Fan smooth running (bearing noises, contact noises, imbalances, etc.).
 - Fan power consumption:
 - Leaks
- ▶ Report all defects to the manufacturer immediately. Remove defects following consultation with the manufacturer.
- ▶ Check the unit and the unit's interaction with the heat carrier circuit of the system again after 48 operating hours, especially on the connections and on the fans, and document the test results.

7.7 Test readiness for operation

- ▶ Ensure that all electrical protective measures are ready to function.
- ▶ Ensure that all working fluid-carrying connections are securely in place.
- ▶ Ensure that all electrical connections (fans) are securely in place.

7.8 Putting the unit into operation for the first time

⚠ WARNING

Danger of injuries and damage to property!

Escaping heat carrier can cause injuries (see "Residual hazards due to the heat carrier glycol", page 28).

You can put the unit into operation, only when:

- The unit has been properly mounted and connected (see "Installation", page 49),
- You have performed a complete acceptance test (see "Perform acceptance test", page 53),
- You have checked the unit's readiness for operation (see "Test readiness for operation", page 54) and
- All safety precautions (see "Safety", page 42) have been taken.

Follow the instructions manual of the system!

Contact the manufacturer immediately if you want to operate the unit under different operating conditions as those defined in the order-related offer documents.

- ▶ Switch on the system including the heat carrier circuit and the electrical system (see installation manual of the system).
- ▶ Activate the unit:
 - Open the valves on the inlet and outlet side of the heat carrier circuit of the system
 - Activate fans
- ▶ Wait until the operating point is reached. Once the operating point is reached, the unit is ready to operate (see instructions manual for the system).

Parameters for setting the operating point, see order-related offer documents.

Operating point:

- Heat carrier flow temperature
- Heat carrier return temperature or circulating heat carrier volume
- Airflow volume
- Air inlet temperature

To ensure the specified operating point is complied with the actuators for the operating point setting must be secured against unauthorized access (e.g. by sealing, screwing on caps, removing hand wheels, etc.).

8 Operation

8.1 Safety

⚠ WARNING

Danger of cutting off, pulling in!



There is a danger of cutting off fingers on the rotating fan blades, injury hazard for the hands and pulling in danger with loose elements such as hair, necklaces or clothing parts.
Do not operate fans without guard grille!

⚠ WARNING

Burn hazard!



Danger of burns if parts are touched (see "Thermal residual hazards", page 27).
Do not touch any parts of the unit without protective gloves when the unit is in operation or if it has not yet cooled down again after operation.



8.2 Putting the unit into operation

To operate the unit, the system must be in operation, including the heat carrier circuit and the electrical system. The unit must be started up by opening the respective valves on the inlet and outlet side of the heat carrier circuit and by connecting to the electrical system as follows (see refrigeration system instruction manual):

- ▶ Switch on electrical system
- ▶ Open working fluid-carrying lines
- ▶ Switch on fans

8.3 Taking the unit out of operation

The units are system components of a refrigeration system, including the heat carrier circuit. The unit is taken out of operation by switching off the heat carrier circuit of the system in accordance with the instruction manual for the system. To do this, the working fluid-carrying lines must be shut off from the system and the fans must be disconnected from the electrical system (see refrigeration system instruction manual):

- ▶ Switch fans off
- ▶ Switch electrical system off
- ▶ Close working fluid-carrying lines
- ▶ Drain the unit: Drain the heat carrier fully see "Residual hazards with disposal", page 33
- ▶ **NOTE! When shut down consider max. operating pressure! If necessary, take precautions to ensure that it cannot be exceeded, or drain the device.**

NOTICE

With shutdown times of a month or longer put the fans into operation for approx. 2-4 hours a month to maintain their functionality.

8.3.1 Shutdown, dismantling and disposal

Safety

⚠ DANGER



Risk of injuries owing to electrical voltage!

Direct and indirect contact with live cables can cause serious injuries or death.

- Have the work carried out only by a qualified electrician.
- Work should be carried out in accordance with local regulations, e.g. DIN VDE 0105/EN 50110.



NOTICE

See "Safety"

Procedure

- ▶ Disconnect all systems from the power supply.
- ▶ Make sure that the system is drained.
- ▶ Follow the steps shown in chapter "Installation" in reverse order.
- ▶ Dispose of the materials separately according to the applicable laws and regulations. The pads can be disposed of with the residual waste.

8.4 Shutting the unit down

⚠ WARNING

Danger of injuries and damage to property!

Escaping heat carrier can cause injuries (see "Residual hazards due to the heat carrier glycol", page 28, and see "Residual hazards caused by pressurised parts", page 30).

Ensure that the maximum operating pressure is not exceeded after the shutdown either!

NOTICE

Danger of corrosion and dirt build-up!

Moisture and dirt must be prevented from entering the unit.

Protect the unit against dust, contamination, moisture and wetness, damage and other harmful influences (see "Safety instructions for set-up and start-up", page 42).

With shutdown times of a month or longer put the fans into operation for approx. 2-4 hours a month to maintain their functionality.

- ▶ Take the unit out of operation (see "Taking the unit out of operation", page 56)
- ▶ Secure the unit:
 - When shutdown consider max. operating pressure (see "Technical data", page 35)! If necessary, take precautions so that it cannot be exceeded.
 - Secure the fan motor drives against switching on again
 - Secure working fluid-carrying lines against pressurizing with working fluid.
 - Protect against damaging effects at the set-up point or intermediate storage location (see "Safety instructions for set-up and start-up", page 42), so that the unit's components are kept properly looked after and the proper intentional use and usability of the unit are maintained. The corresponding storage conditions must be provided for this (see "Storage before installation", page 41); precautionary corrosion protection measures, regular checking of the fans' functionality and regular checks on the shutdown unit must be carried out.
- ▶ Drain the unit: Drain off all heat carrier(see "Residual hazards with disposal", page 33).

8.5 Putting the unit into operation after a shutdown

The unit must be put back into operation in acc. with the system-specific set-up in acc. with the instructions manual of the system as follows:

- ▶ Test the unit's readiness for operation (see "Test readiness for operation", page 54). Perform pressure test and visual inspection for corrosion protection.
NOTE! The pressure test with recommissioning must only be carried out with appropriate media at appropriate test pressure.
- ▶ Put the unit into operation (see "Putting the unit into operation", page 56)

8.6 Changing the unit over to another working fluid

▲ WARNING

Danger of injuries and damage to property!

Considerable dangers can be caused when operating the unit with another working fluid without prior manufacturer approval (see "Improper use", page 24).

The unit must not be changed over to another working fluid without prior written consent of Güntner GmbH & Co. KG!

- ▶ Ensure that the unit manufacturer has agreed to the changeover.
- ▶ Ensure that the right working fluid is re-filled. Ensure that all materials used in the unit are compatible with the new working fluid.
- ▶ Ensure that the permissible pressure is not exceeded.

- ▶ Check that the new working fluid can be used without requiring a new test certificate for the unit. Ensure that classification is complied with.
- ▶ The safety device for the unit must be swapped out or reset.
- ▶ Mixtures with residues of working fluid , for example, must be prevented.
- ▶ All information concerning the new working fluid must be changed accordingly.
- ▶ Change the complete documentation including these instructions and the instructions manual of the system accordingly.
- ▶ Perform acceptance test (see "Perform acceptance test", page 53).

9 Troubleshooting

9.1 Safety

⚠ WARNING
<p>Danger of injuries and damage to property!</p> <p>Faults that are not described in these instructions must only be removed by Güntner . Contact the Güntnerhotline.</p> <p>Faults that are described in these instructions must only be removed by appropriately trained personnel (see "Personnel, care requirements", page 22).</p> <p>With faults that occur during the operation, monitoring and maintenance of the complete system, inform Güntner GmbH & Co. KG immediately.</p>

9.2 Service

Office hours

Tel. +49 8141 242-473
 Fax. +49 8141 242-422
 E-mail: service@guentner.com
 Mon-Thurs: 7.30 am - 5 pm
 Fri: 7:30 am - 13:00

9.3 Troubleshooting table

Fault	Possible cause(s)	Remedy
Fan motor not running	Power supply interrupted	Restore power supply
	Fan blade stuck	Enable fan to rotate freely
Bearing noises	Defective fan motor	Renew bearing or fan motor
Unit vibrating	Defective fan blades	Change fan blades
	Loose fan fixture	Tighten fixtures
Unit capacity not achieved	Heat exchanger is very dirty on the air side	Clean
	Fans not running properly or down	Repair, exchange fans
	Working fluid pressurising defective (temperature and quantity insufficient)	Set working fluid pressurising values (temperature and quantity) to reference values.
Unit capacity not achieved	Insufficient heat exchanger setting	Set heat exchanger setting (concentration, inhibition)

Fault	Possible cause(s)	Remedy
Working fluid escaping	Unit working fluid-carrying components leaking	Switch off working fluid feed and fans, close leak

10 Maintenance

10.1 Safety

10.1.1 Before starting all maintenance

⚠ WARNING

Danger of injuries and damage to property with escaping working fluid! (see "Residual hazards due to the heat carrier glycol", page 28).

Only perform maintenance work – especially welding work – on the leaking unit after completely removing the working fluid from the leaking unit!

Perform the following safety measures before beginning all maintenance work:

- Evacuate/ the unit's heat exchanger
- Clean and blow out the unit's heat exchanger.

10.1.2 With all maintenance work

⚠ **WARNING**

Danger of injuries and damage to property with escaping working fluid! see "Residual hazards due to the heat carrier glycol")!

Escaping working fluid with leaks on the unit can cause the following hazard situations and injuries:



Warns against hot surfaces!
In operation the unit's heat exchanger and pipes have temperatures of over +45 °C. Contact can cause burns.
With heat carrier temperatures over +45 °C there is the hazard of burns on pipe components and distribution pipes. Use hand protection!





Warns against frostbite!
With insufficient frost protection filling and operation in areas with frost hazard the unit can cause frostbite. With units that cannot be drained completely the hazard of frostbite also remains after draining. It is imperative that the proper ventilation be ensured when draining the unit. With pressure test, operation and shutdown of units filled with water or insufficient frost protection filling or insufficient setting of the heat carrier, these are disrupted at minus temperatures.

- Use eye protection!





- Use hand protection!

- Ensure that the unit in question is pressure-free before maintenance work begins or the working fluid is sucked up from the unit in question.
- Power off the electrical system and secure it against unintentional switching on again.
- Separate the unit to be maintained from the heat carrier circuit of the system and secure it.

NOTICE



Danger of damage to property!
With work in the inlet and outlet feeds of the fans and heat exchanger, objects can get into the fans and therefore cause faults and damage on the components.

- Power off the fans before beginning maintenance work and secure them against switching on again.
- After the work has finished do not allow any objects to get back into the inlet and outlet feeds of the fans or the set-up room.

10.1.3 After all maintenance work

⚠ WARNING
<p>Danger of injuries and damage to property owing to escaping heat carrier(see "Residual hazards due to the heat carrier glycol", page 28)!</p> <p>Perform the following safety measures after finishing all maintenance work:</p> <ul style="list-style-type: none"> • Ensure the switching and activation devices, the measuring and display devices and the safety devices function properly. • Ensure the working fluid fittings are functioning. • Check the identification of the pipelines and ensure this is visible and legible. • Check the fixing and corrosion protection of the components in question. • Ensure that the electrical connections (e.g. fans and are functioning). • Perform a pressure test and a leak tightness test (see instructions manual of the system). • Perform an acceptance test (see "Perform acceptance test", page 53) • Perform a pressure test (see instructions manual of the system).

10.2 Inspection and maintenance plan

The checks to be performed are listed in the following sections as time-scaled checklists.

10.2.1 Fans

The manufacturer's operating specifications take priority for this component. The Güntner GmbH & Co. KG recommends proceeding in accordance with the following inspection and maintenance plan:

d = daily, w = weekly, m = monthly, y = yearly				
Work to be performed	d	w	m	y
Check the fans for dirt build-ups. • With dirt build-ups: Clean fans (see "Clean unit", page 66).				X *
Check the fan drive for smooth running. • Vibrations on the unit: remove imbalances • Where required, tighten and correct blade fixtures and blade settings				X *
Fan bearing: Running sound and smoothness changes • Replace fan				X *
Fan motor: Is a new bearing due? • Replace fan				X *
Fan wheel: corrosion on bolts (with threaded blades) • Replace fan				X *
Fan blades: Corrosion or damage on blades • Replace fan				X *

*) Recommended: every six months

10.2.2 Unit heat exchanger

⚠ WARNING				
Danger of injuries and damage to property owing to escaping heat carrier(see "Residual hazards due to the heat carrier glycol", page 28)!				
d = daily, w = weekly, m = monthly, y = yearly				
Work to be performed	d	w	m	y
Check heat exchanger for dirt build-ups. • With dirt build-ups: Clean heat exchanger (see "Clean unit", page 66).				X*
Check heat exchanger's general condition. • Damage found: Repair damage				X*
Check heat exchanger's operating point (see "Operation", page 56). • If change in fan capacity found: Restore required system-side conditions (Including heat carrier circuit). • If change in surface temperatures found: Restore required system-side conditions(Including heat carrier circuit) .				X*
Change in heat exchanger setting found: restore required heat exchanger setting (concentration, inhibition)				X*
Check heat exchanger and connections for tightness. • Repair unit sections (see "Remove leaks", page 65instructions manual).				X*
Check heat exchanger for working fluid pressurising. • Restore required heat carrier-side conditions.				X
Check heat exchanger for corrosion. • Corrosion or damage on core tubes, fins, support structures, tube connections, fixtures: repair unit sections affected.				X*

*) Recommended: every six months

10.3 Maintenance work

10.3.1 Remove leaks

⚠ WARNING
Risk of injuries owing to heat carrier(see "Residual hazards due to the heat carrier glycol", page 28)!
<ul style="list-style-type: none"> • Have leaks removed as quickly as possible by an expert. • Do not fill with a working fluid other than that specified in acc. with the order-related offer documents! • Only put the unit back into operation when all leaks have been repaired.

- ▶ Perform all work including pressure, acceptance and functional test (see "Perform acceptance test", page 53, and see "Test readiness for operation", page 54 instructions manual).

10.4 Clean unit

10.4.1 General

The following applies for cleaning: The operator must ensure that the cleaning agents are environmental friendly and compatible for the materials in the system. Harmful to the environment substances, e.g. acid-forming, are forbidden.

- ▶ Clean casing by rinsing with warm water (approx. +25°C) and/or with environmentally friendly cleaning agents.
- ▶ Rinse thoroughly with water after using cleaning agents.
- ▶ Allow casing to dry completely.
- ▶ Check working fluid-side and electrical connections (see "Test readiness for operation", page 54 instructions manual).

10.4.2 Defrost heat exchanger

- ▶ Drain the unit (see system).
- ▶ Shut off the unit (see system).
- ▶ Power off the fans (see system).
- ▶ Clean the heat exchanger with one of the following procedures:
 - Cleaning with compressed air (see "Cleaning with compressed air", page 67)
 - Hydraulic cleaning (see "Hydraulic cleaning", page 67)

NOTICE

Danger of damage to property!

The fins can be damaged with too high a pressure, too small a distance or a cleaning jet that hits the fins at an angle. Mechanical cleaning with hard objects (e.g. steel brushes, screw drivers, or similar) damages the heat exchanger.

- Use a pressure of max. 50 bar with hydraulic cleaning and max. 80 bar with cleaning with compressed air!
- Maintain a minimum distance from the fins of 200 mm!
- Always aim the jet vertically (max. ±5 degree deviation) at the fins!
- Do not use any hard objects when cleaning!

- ▶ Switch fans on (see system).
- ▶ Open drain side (see system operating instructions manual).
- ▶ Open inlet side (see system operating instructions manual).

10.4.2.1 Cleaning with compressed air

- ▶ Blast heat exchanger with compressed air (max. 80 bar pressure) to remove dirt and contaminants.

NOTE! Hold the jet of the compressed air cleaner vertically with respect to the heat exchanger (max. deviation of ± 5 degrees) to prevent fins bending.

10.4.2.2 Hydraulic cleaning

WARNING



Warns against dangerous electrical voltage!

Direct and indirect contact with voltage-carrying parts of motors and electrical lines can cause serious injuries or death. Water and cleaning agents conduct electricity.

- When working with water or steam jets, power off the fans and secure them against switching on again.

NOTICE

Danger of damage to property!

Water or steam jets can damage fans, electrical lines or other components.

- Ensure that electrical connections and motors, as well as components and stored goods at the set-up point are not touched by water or steam jets. Cover these if required.

- ▶ Heavier moisture or greasy dirt must be removed with a high-pressure water jet (max. 50 bar pressure), steam pressure jet (max. 50 bar pressure), min. 200 mm distance with flat jet nozzle, or using neutral cleaning agent where applicable, always against the airflow direction. Ensure here:
 - With oily and greasy dirt it helps to add a cleaning agent to the water.
 - When applying chemical agents ensure that they are not aggressive towards the unit's materials. Rinse the unit off after the treatment.
 - Cleaning should be done from inside to the outside (but always opposing the dirt on-set) and from top to bottom, so that the dirt can be removed without returning.
 - Hold the jet of the cleaner vertical to the fins (heat exchanger – max. deviation of ± 5 degrees) to prevent fins from bending.

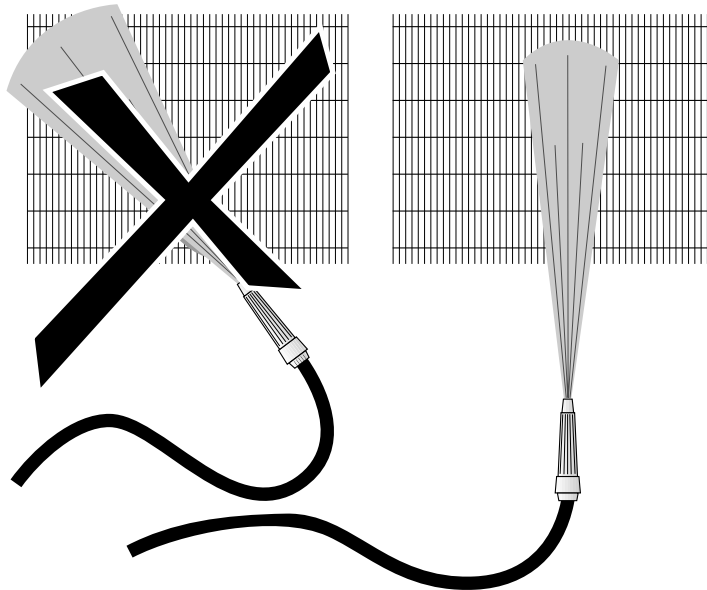

► Continue cleaning until all dirt has been removed.

10.4.2.3 Cleaning the pipe insides

Rinsing with solvents removes dirt build-ups formed by limescale, paint-type layers, oil residues, etc. A solvent appropriate to the deposits should always be selected. The following chemicals have been proved to be useful:

- 10%-content formic acid
- Trichlorethylene for organic layers

Generally speaking, the cleaning agent must be suitable for copper and/or non-ferrous metals. The information can be found in the product data sheet for the cleaning agent (request from the relevant manufacturer).

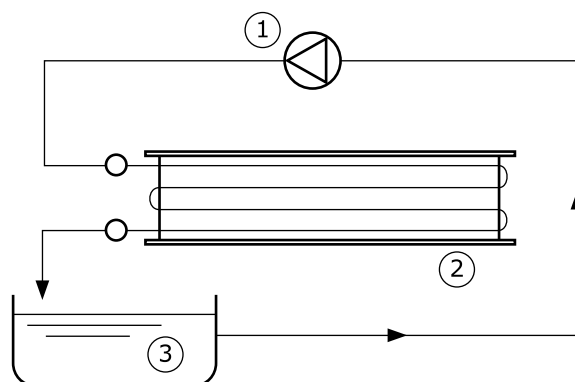

Cleaning principle:



- 1 Pump
- 2 Heat exchanger
- 3 Containers for catching cleaning liquid

Chemical cleaning is applied where the dirt is stubborn or with heat exchangers with lime scaled pipes and collectors.

- ▶ Select the pump's supply rate so that a speed that is adjusted to the cleaning effect is achieved (2.5 to 5 m/s).
- ▶ Neutralise and rinse the heat exchanger well after cleaning.

⚠ WARNING	
 	<p>Toxic hazard! Trichlorethylene is harmful to the health and highly narcotic: inhalation of air with 200 ppm causes tiredness. It has been classified by the MAC Commission as carcinogenic (category 2) and germ cell mutagenic (category 3B). It must be identified as "Toxic". Acute poisoning causes brain damage, blindness and destruction of the smell and taste senses.</p> <ul style="list-style-type: none"> • Only use trichlorethylene in closed systems with complete recovery. • Exclude all open flames or spark sources. • Smoking is forbidden. • Protect the skin and eyes with suitable protective materials.

10.4.3 Cleaning fans

⚠ WARNING	
<p>Danger of cutting off, pulling in!</p> <p>There is a danger of cutting off fingers on the rotating fan blades, injury hazard for the hands and pulling in danger for loose elements such as hair, necklaces or clothing parts.</p> <ul style="list-style-type: none"> • Power off the unit before you begin maintenance work. Secure the unit against unintentional switching on again by removing the electric fuses for the unit. Secure the unit with a suitable warning sign referring to unintentional switching on. • Put fans and guard grilles that were removed or opened for maintenance back into their original status without fail before you put the unit back into operation! 	

Dirt deposits on the fans, the streamers or air outlet connectors (if installed) and the fan protection grilles must be removed regularly because they can lead to imbalances or capacity loss or even destroy the fans. The fan motors themselves are maintenance-free.

- ▶ Power off the unit and secure it against unintentional switching on.
- ▶ Clean fans with one of the following procedures:
 - NOTE! Danger of damage to property! Mechanical cleaning with hard objects (e.g. steel brushes, screw drivers, or similar) damages the fan. Forbidden!**
 - Cleaning with compressed air: Blow fans with compressed air (max. 10 bar pressure; min. distance 200 mm) to remove dirt and contaminants. Continue cleaning until all dirt has been removed.
 - Cleaning with compressed air and brushes: Remove dry dust or dirt with a brush, a hand brush or with compressed air (max. 10 bar pressure, min. distance of 200 mm) or with a powerful industrial vacuum cleaner. Ensure here: use soft brushes (no steel brushes or similar)! Continue cleaning until all dirt has been removed.
- ▶ Mount protection grilles, streamers or air outlet connectors (if installed)
- ▶ Switch unit on

11 Plans/diagrams

11.1 Electrics documentation

11.1.1 Fan motor connection diagram

See motor terminal box cover inside on the fan.